

up-to-date electronics for lab and leisure

ELEKTOR 13

Integrated antenna

Indoor aerial with built-in
preamp for VHF-FM

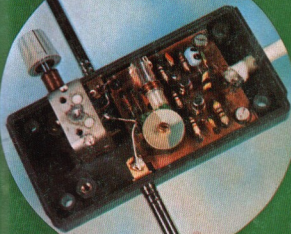

Review by

EQUIN
Versatile logic probe
Digisplay

May 1976 40p

contents

selektor	506
missing link	508
integrated indoor fm aerial	510
This indoor FM antenna integrated with its specially designed amplifier will prove to be the long wished-for solution for those who are dissatisfied with the quality obtained from more or less makeshift aerials suspended from the living room ceiling, but are not in a position to erect a proper outdoor aerial.	
homemade display — M.W.M. Henst	514
Large displays are, unfortunately, expensive. This article describes a simple method of constructing a 'homebrew' display with 40 mm (approximately 1½ in) characters.	
preco (2) — T. Meyrick	516
As described in the previous issue, the Preco is a high quality preamplifier/control amplifier system. It has the unusual feature that the control amplifier can be used as a remote hand-held unit. The preamplifier was described in part 1; the hand-held control amplifier will be discussed here, with construction and interconnection details.	
image width control	523
equin (2)	525
The first part of this article (Elektor 12, p. 448) outlined the thinking that led to the Equin amplifier design. In this part of the article, the 'paper' amplifier is converted into a ready-to-build recipe.	
supply decoupling	535
A circuit is only as good as its power supply. Even the best designed circuits can be upset by supply ripple, poor regulation, mains transients and power supply instability. IC voltage regulators have taken much of the donkey work out of power supply design for many applications, but the problems do not always end there.	
digisplay — M.G. Fishel	538
This logic tester displays the states of sixteen binary signals (either '0' or '1') simultaneously, in the convenient form of a 4 x 4 matrix on an oscilloscope screen.	
tv tennis extensions (3)	544
This article gives circuits for producing synchronous sound effects that can be added to the original TV tennis game. Some variants of the basic game are also described.	
masthead preamp	550
On the fringes of the service area of an AM transmitter it is often difficult to obtain satisfactory reception, especially of stereo transmissions, even when a good aerial and a first class FM tuner are used. In such cases a masthead aerial preamp may provide a solution.	
versatile logic probe — M. Vanhalst	553
The versatile logic probe provides information about logic levels and the duty-cycle of pulse trains in TTL and DTL circuits and is unusual in that it uses a 7-segment LED display for the readout, instead of the more usual discrete LED's.	
market	556

SELEKTOR SELEKTOR! SELEKTOR SELEKTOR!

Magnets for separating blood

For the first time the iron content of red blood corpuscles has been used to separate them from other blood components. The red cells are magnetically attracted to a very simple form of steel wool filter, a technique that promises to be valuable in research as well as in medical practice.

Red blood cells are small disc-like bags, 8 μm in diameter, occupying 45 to 50 per cent of the total blood volume. They contain a solution of the blood pigment haemoglobin. A molecule of haemoglobin has approximately 10 000 atoms, of which only four are iron. The iron atoms are essential to the respiration process and they give the blood its characteristic red colour. They are important in the separation process because through them there is enough iron present to make the red blood cells very weakly paramagnetic when in their de-oxygenated state, so that they experience a force in the presence of a magnetic field.

In 1968 Henry Kolm of the Massachusetts Institute of Technology introduced the concept of the high gradient magnetic separator, a device that has been extensively adopted for cleaning weakly magnetic impurities from china clay. It has greatly increased the 'brightness' of the clay, so enhancing its value for coating paper. A typical HGMS device, depicted in diagram 1, consists simply of a pad of steel wool in a magnetic field. This background field magnetizes the steel wool which, because of the small dimensions of its strands, introduces a very large field gradient, attracting the red blood cells to the wire and holding them back while other blood components pass freely through. When the magnet is switched off, the steel wool demagnetizes and the red blood cells can be washed off into a separate container. The results of a typical experiment are shown in diagram 2. The magnet is switched on and a 2-millilitre (ml) sample of blood is applied to the top of the filter. It is carried through by a steady flow of sodium dithionite solution, which also serves as a reducing agent to keep the blood de-oxygenated. The volume of blood solution flowing through is measured and analysed for red cell content. Apart from the small hump to the left of the graph, which

marks the initial blood application, the red cell count is very low until the magnetic field is switched off. Then all the red cells held on the filter are washed off and there is a sharp increase in the red cell count. The visible effect is a change from an almost clear fluid to the deep red colour of blood.

The magnetic field applied in the experiments so far has been about 2 tesla, a level that is readily obtained from an electromagnet. The blood flow rates are low, although it is possible to process 500 ml (1 pint) of blood in about 10 minutes. Experiments indicate that if we double the rate of blood flow, we need to double the magnetic field to achieve the same separation effect, so we are studying different designs of filters and filter materials to produce a more efficient separation process. In handling blood it is important to see that no damage is caused to the red cells. In our experiments we have examined them with a scanning electron microscope, which was used to produce the photograph below. So far as we can tell, the filtration process causes no serious damage. Early on we did, however, discover that it is important to use smooth wire for the filter. We found that 'household' steel wool ruptured many of the red cells when they were washed from the wire after filtration. We attributed this to its extremely rough and irregular surface which, after all, is intended for scouring. The wire wool that we have now

adopted as our standard material has an almost smooth surface and the strands have a diameter of 25 micrometres.

Although the technique is at no more than the research stage there is considerable interest in it for various applications. For example, there is often a need for blood which is free of white cells. This is particularly so in kidney transplants, because antibodies to white cells can lead to rejection reactions. HGMS offers a potential supply of concentrated red cells that can be used to produce 'blood' with a low white cell count.

To keep red cells fresh for long periods they are frozen in glycerol. Although it serves to protect the blood during freezing and thawing procedures, removing the glycerol before the blood can be used poses problems. Here the HGMS technique offers a new approach. Another interesting possibility is its application in kidney machines, whose job is to take blood from the body, clean it of impurities and return it. The impurities are mainly in the white cells and plasma, and the red cells tend to impede the blood cleaning process.

Red cells are also easily damaged in the machine. We envisage removing the red cells by an HGMS unit before the blood passes into the kidney machine, and returning them to the clean blood before it is re-admitted to the body. One advantage of the HGMS technique over conventional centrifugation is that it is easy to adapt it to continuous flow

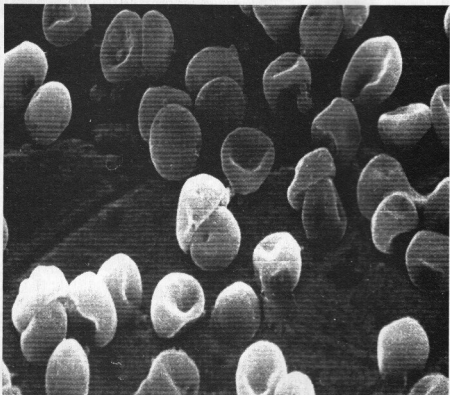

Human red blood cells under a scanning electron microscope.

SELEKTOR SELEKTOR: SELEKTOR SELEKTOR

thrown at the right moment and that the cars roll smoothly into position on the sidings so that they can be re-coupled. They should neither collide nor come to rest too far apart.

The two Siemens process computers at



work in the Mannheim switchyard are taking care of these problems. To do the job they first need to know several facts about the incoming cars, the necessary data is fed to them by telex after each car has arrived. The computer system uses this information to compile an uncoupling list which serves as a basis for controlling the switches. The system must also be kept constantly informed as the cars go through the uncoupling process so that it can throw the switches at just the right moment. This is taken care of by sensors built into the rails which report each passing car to the computers.

Re-assembling the freight cars on the sidings ready for re-coupling is a much more complex process, and is also carried out automatically under computer control. As the cars roll down the incline their length is measured by radar equipment, the axle load is registered by means of resistance strain gauges and the speed is measured at various points. The computers use this information to control the rail brakes

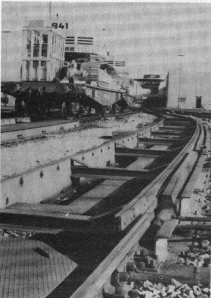

(in photo 2, the thick beams along side the rails) located at the foot of the double incline and at the start of the sidings, as well as special advancing systems which slowly push each car up to join the others by means of carriers situated between the rails.

The experience gained so far at Mannheim has shown that the use of process computers for automatic sorting not only speeds up the process but also permits the cars to be handled more safely and more economically. For example, the 36 stop-block layers previously needed for stopping cars that were moving too fast are no longer required, and there has been a 90% reduction in damage occurring during the marshalling process.

*Siemens AG
Zentralstelle für Information
D-8520 Erlangen 2, Postfach 3240
Federal Republic of Germany*

All-band anti-bandit

For special use in monitoring and sur-

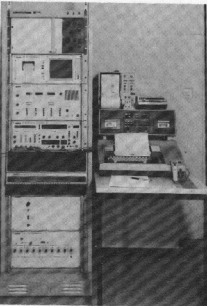

veillance of radiocommunications reaching far into the UHF range, Schlumberger have developed the receiver system 'FAHD'. Due to the use of a computer-controlled frequency synthesizer serving as a local oscillator, this installation achieves automatic operation at extremely high speed. It is possible e.g.

- to measure the field strength of up to 10 000 different incoming frequencies per second,
- to determine simultaneously the field strength and the offset frequency as well as the FM deviation and the AM depth of up to 10 receiving channels,

- to re-select a once detected receiving frequency within less than one millisecond.

With the same rapidity, switching-over from channel reception to frequency analysing can be achieved, in order to obtain a 'finger-print' of the received transmitting station. Another advantage of computer control is given by the fact that known transmitting stations can be faded out in order to track interconducted transmissions over considerable frequency intervals, and to identify intermodulation distortion from powerful transmitting stations. Two types of this receiving equipment have already been installed with all radio monitoring stations of the German Federal Post Administration, covering the frequency ranges from 10 kHz to 180 MHz and from 10 kHz to 960 MHz. As this equipment is of modular construction, it may also be used in a simplified arrangement for less exacting requirements.

*Schlumberger GMBH,
Ingolstädter Straße 67a,
8000 Munich 46, West Germany*

THE MISSI
NGLI...
LINK THE
MIS
SING
LINK THE
MISSING
THE MISS

Modifications to
Additions to
Improvements on
Corrections in
Circuits published in Elektor

Morse Typewriter

On page 227 (issue 10) in figure 2 the type number of a triple, 3-input NAND-gate IC is incorrectly given as 1710. This should, of course, be type 7410.

TV Tennis

On page 1117 (issue 7) in figure 7, T3 and T4 are transposed. As these transistors are of the same type this does not affect the operation of the circuit, but this point should be noted if fault-finding is necessary.

Build-it-yourself!

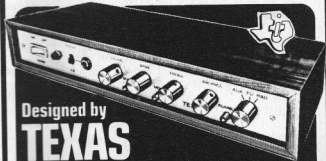

Designed by
TEXAS

Featured by **PRACTICAL WIRELESS**
SOLE U.K. DISTRIBUTORS - HENRY'S

Build the Texan stereo amplifier, then you can be doubly proud! For a start, you'll own a superb home entertainment unit. And have had all the pleasure of doing it yourself, with the Henry's kit.

Look at the Texan specification

Incorporating fully integrated stereo preamp and power amp, with 6 IC's, 10 transistors, 8 rectifiers and zener diodes. Plus stabilised, protected circuitry, glass fib pcb. Gardena's low-field low-line mains transformer; all facilities and controls. Slim design. Chassis 16 1/2" x 8" x 2" overall. 20 watts per channel RMS, less than 0.1% distortion at 1 kHz.

- ★ Can't be built Slane by stage. Ask for leaflet 20
- ★ Everything necessary supplied. Full after sales service and guarantees.

KIT PRICE
£35.00
inc. VAT + £1 p.p.

Build and tested
£45.00 inc. VAT
+ £1.00 p.p.

THE NATURAL FOLLOW-ON - THE TEXAN FM TUNER KIT!

KIT PRICE
£25.95
inc. VAT + 50p p.p.

Build the matching Texan stereo tuner! Features advanced vernier tuning. Phase lock loop decoder. Professionally designed circuit. Everything you need is in the kit. From the glass fibre pcb to the cabinet itself. Excellent spec. 2.5 uV aerial sensitivity. 500 mV output (adjustable). Tuning range 87-102 MHz. Mains powered.

Build and tested £30.95 inc. VAT + 50p p.p.

VIDEO SPORT

... all the electronic excitement you could wish for!

★ OVER 10,000 ALREADY SOLD ★ IDEAL GIFT

An up-to-the-minute game. Plugs into your own TV aerial socket. Switch on. And you're away! Choose your game - football, tennis or hole-in-the-wall. Absolutely safe. For you. Your children. And your TV. Mains powered. List Price £42.50



HENRY'S PRICE - ONLY £29.50 inc. VAT + 50p p.p.

WHATEVER YOU DO, DON'T FORGET YOUR LATEST HENRY'S CATALOGUE!



For this new edition, we have made hundreds of changes and additions. It has over 200 pages, containing virtually everything for amateurs and professionals. And you'll have no bother at all finding everything you want, because there's a complete alphabetical index as well as a section index. Together, they put you right on course for the items you need. From Sinclair projects to educational kits. Oscilloscopes to panel meters. Coils to capacitors. Transistors to valves. Loudspeakers to microphones - all at competitive prices. Over 200 pages of what's latest - just for you! So send now for your copy.

- Over 5000 items inside!
- Every copy contains a free 50p voucher.
- Many new items.
- Over 200 pages.

ONLY 50p

FREE to Educational Establishments when ordered on official headed notepaper.

25p cart./pack

Henry's

SELF-SERVICE CENTRES 404 and 309 EDGWARE ROAD, LONDON W2
Bargains galore - Call in and see for yourself!

404/6 EDGWARE ROAD, LONDON W2 01-402 8381
LOWER SALES FLOOR, 231, TOTTENHAM CT. RD., LONDON W1 01-636 6681

NEW MIDLANDS STORE 94, 96 UPPER PARLIAMENT STREET, NOTTINGHAM. 0602-40403
All mail to Henry's Radio, 303 Edgware Road, London W2



HIGH QUALITY PROFESSIONAL AUDIO MODULES

Over the years there has been a growing demand for high quality audio power amplifier modules. At last and never before has such quality been offered at such a reasonable price.

All our modules at JPS are fitted with full output protection, and have a super High Stability Integrated Circuit front end containing within itself no less than twenty transistors.

All JPS products carry a two year guarantee.



POWER OUTPUT: **150**
170 W R.M.S.

FREQUENCY RESPONSE:
D.C. - 21kHz - 0.2dB

POWER BANDWIDTH:
D.C. - 20kHz - 0.2dB

SLEWING RATE:
8.4V per microsecond

T.H.D.: .03%

INPUT SENSITIVITY: *
0dB (0.775V) 150 W

INPUT IMPEDANCE: * 47k

HUM AND NOISE:
>100dB below 150 Watts

DAMPING FACTOR:
>200 to 1kHz

POWER REQUIREMENTS:
±55V D.C.

PRICE: £32.02 (inc. VAT)

POWER OUTPUT: **50**
65 W R.M.S.

FREQUENCY RESPONSE:
D.C. 21kHz 0.2 dB

POWER BANDWIDTH:
D.C. 20kHz 0.2 dB

SLEWING RATE:
8.6 V per microsecond

T.H.D.: .03%

INPUT SENSITIVITY: *
0dB (0.775V) 50W 8 ohms

INPUT IMPEDANCE: * 47k

HUM AND NOISE:
>100dB below 60W

DAMPING FACTOR:
>200 to 1kHz

POWER REQUIREMENTS:
±35V D.C.

PRICE: £19.20 (inc. VAT)

*At a small extra charge, these parameters may be changed to order. Impedance: Max 250K - Sensitivity: 100mV RMS

As both modules are totally D.C. coupled, they may also be ordered as D.C. amplifiers, the Power Response then being -0dB + 0.5dB. D.C. to 20 kHz

POWER SUPPLIES below are available upon request:-
PS50 - (Drives single 50 Watts) £11.07 PS150/1 (Drives single 150 Watts) £18.15
PS50/2 - (Drives dual 50 Watts) £14.57 PS150/2 (Drives dual 150 Watts) £23.00
N.B. It is not recommended that the D.C. Modules are used for audio installations as extreme low frequencies damage loudspeaker systems.

Please send me further information

I herewith enclose Cheque/Postal Order for £..... made payable to JPS Associates.

For 0 150 watt modules @ £32.02 (inc. VAT)

For 0 50 watt modules @ £19.20 (inc. VAT)

Quantity Discounts upon request

NAME

ADDRESS

Postal Code

All JPS Products carry a full Two Year Guarantee.



BELMONT HOUSE
STEELE ROAD
PARK ROYAL
LONDON NW10 7AR

TELEPHONE 01-961 1274

integrated indoor fm aerial

This indoor FM antenna integrated with its specially designed amplifier will prove to be the long wished-for solution for those who are dissatisfied with the quality obtained from more or less makeshift aerials suspended from the living room ceiling, but are not in a position to erect a proper outdoor aerial.

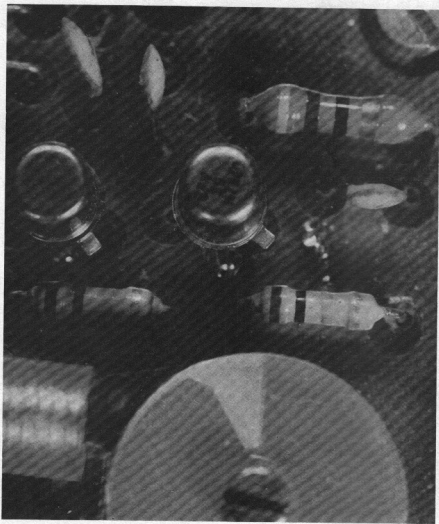

This article is written for the benefit of listeners in the possession of efficient FM stereo equipment that cannot give a good account of itself due to the fact that the RF signal from the antenna is of insufficient level and/or quality. These conditions can prevail not only in the case of those who live in lodgings or temporary apartments, but also in the case of occupants of blocks of flats where a compulsory but not quite reliable central antenna system has been installed. Frustrated listeners, unwilling to bend to circumstances beyond their control, must then resort to self-constructed antennas to be placed in the loft or in the sitting-room itself. The latter place, however, precludes the installation of a bulky antenna array,

and necessitates the use of a more austere system.

For the budding indoor aerial constructor, figure 1 illustrates two simple dipole designs. The 240/300 Ω version is made of a length of ribbon cable tapped at the centre and with the conductors joined at the ends; the 60/75 Ω version is even more simple and consists merely of a ribbon cable split over a length of 75 cm (30 in) and spread out.

However a simple dipole may not have enough gain. The only way to compensate for insufficient gain is, the addition of an RF signal amplifier. Continuing this line of thought, it seems logical to combine the dipole and the amplifier into a self-contained 'electronic antenna'. The basic requirements which

the antenna system will have to perform involve a set of design targets that differ from the commonly available aerial amplifier. The object is not to render a servicable RF signal better still, but to turn a poor signal into a servicable one. The main feature of the integrated system will be high gain; side effects such as intermodulation will not, however, be disregarded.

The following list of amplifier requirements will give an indication of the problems to be solved in the design of the integrated system:

1. reduced size;
2. highest possible gain;
3. very low noise content, preferably lower than found in the majority of FM tuners;

4. stability under all conditions;
5. relatively straightforward and inexpensive construction;
6. easy tuning-up and operation;
7. if feasible, supplying DC power via the cable that connects the integrated antenna to the FM receiver.

Requirement 7 gives occasion to some further ideas. It would be an attractive idea to avoid the complication of a separate power supply, by letting the receiver supply the DC current.

In many cases this will not be difficult to accomplish, provided the current drain can be kept reasonably low. Combining the power requirement with item number 2, highest possible gain, seems to point away from a design using FET's. Although FET's have the advantage of low noise and high immunity from intermodulation, a FET stage with reasonable gain will usually draw some 10 milliamps, and even then the gain is inferior to that of a good bipolar RF transistor. Using two FET stages would enable sufficient gain to be obtained. However the power requirement of

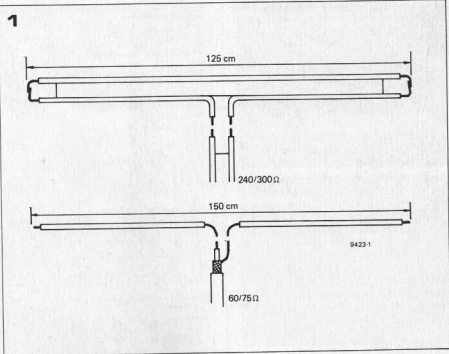

2

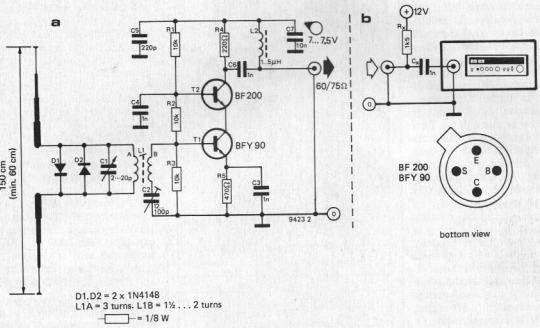

about 20 milliamps could not be safely drawn from the FM receiver. A more detailed evaluation of requirement 3 (amplifier noise) will lead to the following observations. A FET stage painstakingly optimised for minimum noise (usually rendering a rather low gain figure!) has a noise content of about 1 dB at 100 MHz. The noise figures for most commercially available FM receivers are seldom lower than about 4.5 dB. For this reason, there is little point in sacrificing high gain in the interest of an unusually low noise figure. It has been found that a well-designed antenna amplifier using good high frequency transistors will not exceed about 2 dB of noise.

Figure 1. Indoor dipoles made of standard ribbon cable.

Figure 2. Circuit diagram of the integrated indoor antenna. Figure 2b shows power supply connections to the amplifier.

Circuit Description

Since most modern FM receivers are supplied with 60 or 75 ohm antenna inputs, the amplifier was designed to match this impedance.

To comply with the requirements, especially those regarding the gain and stability, it was found that the most favorable design would be one featuring cascaded transistors. The types selected (BFY 90 and BF 200) are known to be excellent VHF performers.

The antenna proper is an open dipole made of two metal knitting needles or thin telescopic antennae; for optimum matching the overall length must be 150 cm. If space is very restricted and

a weaker signal is acceptable, shorter antennae may be used, but the over-all dipole length should not be under 60 cm (2 ft).

The antenna is an integral part of the amplifier input circuit formed by C1 and L1A (see figure 2), diodes D1 and D2 strapped in reverse-parallel serving as a protection against excessively strong signals. Variable capacitor C1 is used to tune the antenna to maximum signal strength of the desired station. This tuning control is an essential feature of the system. Secondary winding L1B applies the signal to the input transistor T1. The series circuit L1B/C2 are adjusted for an optimum impedance match by setting C2.

The cascode stage T1 and T2 gives an appreciable gain. It has been assumed that the power will be supplied via the coaxial cable that runs to the FM receiver. Inductor L2 prevents the amplified signal from being short-circuited through the power supply connection.

Power Supply

If it is intended to have a separate power unit care must be taken that C_X and R_X (see figure 2b) are mounted as near as possible to the aerial input terminals of the FM receiver. It should, however, be remembered that the most convenient and elegant solution, from a technical point of view, is to use the supply of the FM receiver. This involves, admittedly, a minor modification inside the set. This modification is not likely to cause complications.

Figure 3 indicates in more detail how the job can be carried out. Most receivers are powered by 12 or 15 volts requiring a 1K5 or 2K2 series resistor (R_X), respectively. In other cases R_X can easily be calculated by using this formula

$$\frac{\text{Receiver voltage} - 7.5 \text{ V}}{3 \text{ mA}} = R_X.$$

The printed circuit board

In order to avoid disappointment when the design is put to work, it will hardly be necessary to mention here that construction of VHF circuitry must be carried out with care and insight into the problems that may arise.

In the antenna amplifier the first stage features the rather 'ticklish' type BFY 90, prone to burst into oscillation at the slightest provocation, which turns a sloppily built FM preamplifier into a more or less efficient FM transmitter. To avoid problems of this kind, the p.c. board (see figure 4) was laid out with extreme care. The components are not arranged to 'look good' but 'to work well'. Furthermore the board is double-sided, one side being used as screening. The tuning capacitor C1 is not mounted directly on the p.c. board, so that almost any type commercially available can be used.

Constructional notes

The four studs that interconnect the common copper areas of the top and

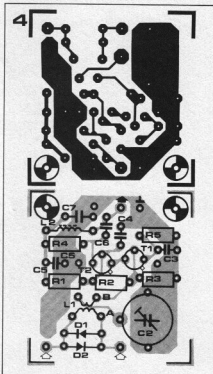
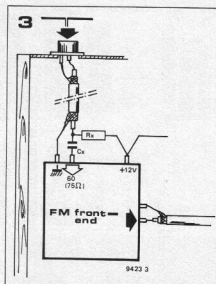

Parts List

Resistors (all 1/8 watt)

- R1, R2, R3 = 10 k
- R4 = 220 Ω
- R5 = 470 Ω
- R_X see text

Capacitors

- C1 = variable 2 to 20 p
- C2 = trimming capacitor 12 to 100 p
- C3, C4, C6,
- C_X = 1 n ceramic
- C5 = 220 p ceramic
- C7 = 10 n ceramic (or MKM)

Semiconductors

- D1, D2 = 1N4148
- T1 = BFY 90
- T2 = BF 200

Inductors

- L1 = tuning coil see text
- L2 = 1 to 5 microH choke

bottom of the p.c. board are of essential importance. These connections are made by inserting short lengths of wire at the common output terminal and at the three other empty holes in the board. The studs must be soldered at both sides of the board. This ensures good screening.

The next step could be mounting the transistors. Both T1 and T2 must be fitted close to the board with a maximum of ¼ inch of clearance. Since no fourth hole is available for the case leads of these transistors, they should be soldered straight to the copper area on the component side of the board as shown in figure 5. The use of a double-sided board involves a construction in which the components are mounted floating above the board surface, which can best be done by temporarily sliding a piece of cardboard or similar spacer underneath the component before soldering.

All resistors are 1/8 watt. Capacitors must be of the high quality ceramic disc type.

Constructors are advised against winding L2 themselves. Chokes of the proper type can be bought from many component stores where they are in good supply at reasonable prices. The inductance is not critical and may be anything between 1 and 5 microH.

Inductor L1, on the other hand, must be specially made. It is wound on a 6 mm (¼ inch) diameter former with a ferrite core with a permeability $\mu_r = 12$. Our prototype amplifier uses a Kaschke type KHS/20-44/20 with a green marker slug model G5/0.75/13 type K3/12/100. Figure 6 shows its construction. Coil L1A consists of 3 turns of 0.6 mm (22 S.W.G.), silver plated copper wire; L1B has 1½ or 2 turns of 0.5 mm enamelled copper wire (S.W.G. 24).

The photograph illustrates how the two small telescopic antennae, the tuning capacitor, and the p.c. board can be integrated into a compact unit. It is imperative to make all wiring, to C1 and the dipoles, as short as possible.

Tuning-up Procedure

After the antenna unit is connected to the FM receiver, verify that the voltage across C7 is about 7.5 volts. If not, correct the resistance of R_X.

Begin tuning-up by finding a station near the high end of the band and setting C1 and C2 to minimum capacitance.

Turn the L1 slug to obtain maximum signal strength on the FM receiver tuning indicator. Adjust C1 and C2 for lowest noise. Then re-adjust the L1 slug for maximum signal strength, and leave it there. Finally find a signal at about 95 MHz and adjust C1 and C2, for maximum strength.

Provided that the dipole length remains unaltered, the L1 and C2 settings will remain the same. Accurate peaking-up on other stations can now be carried out by means of the tuning capacitor C1.

Performance

Although gain measurements do not,

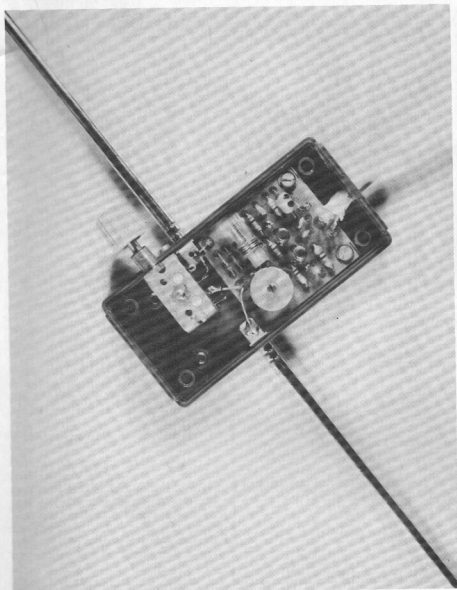

Figure 3. RF and power connection to the FM receiver.

Figure 4. Component lay-out and printed circuit board. (EPS 9423). The connections between the antennae, C1 and the board must be kept as short as possible.

Figure 5. Emitter, base and collector leads of both transistors are inserted into the corresponding holes in the board; the case lead is soldered straight to the copper surface.

Figure 6. Tuning coil L1 shown in close-up.

Figure 7. Spectrum analyser display of the 84-104 MHz VHF-FM band, as picked up by a $\frac{1}{4}$ -wave rod.

Figure 8. and as picked up by the integrated FM antenna.

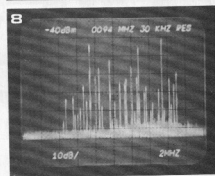
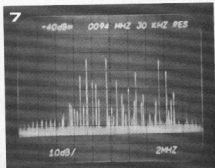
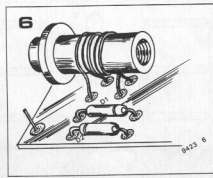
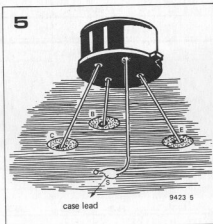
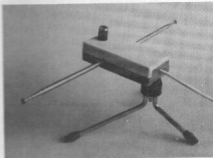

usually, present many complications, the problem with this integrated design is the impossibility of measuring the amplifier separately, because the amplifier and antenna are one unit.

However, it is possible to estimate the performance of the integrated system by comparing it with other systems. The first possibility that comes to mind is to use a high frequency spectrum analyser.

A simple $\frac{1}{4}$ -wave rod antenna was used as a reference; the measurement result is shown in figure 7. The spectrum analyser was set at 30 kHz resolution, 2 MHz per division and 94 MHz center frequency. The resultant display shows the performance of this simple antenna in the 84-104 MHz band. The vertical scale is 10 dB/div. and the noise level (i.e. the grass at the bottom of the picture) is approximately -100 dBm, corresponding to about 2 μ V.

Without altering any of the settings of the analyser, the integrated aerial was now measured. Figure 8 shows the result. The difference is obvious! The amplifier was tuned to 99 MHz for this test, and the gain at this frequency proves to be about 14 dB. Not all transmitters are boosted equally, of course, owing to slight differences in aerial orientation.

A separate noise measurement showed that the noise figure must be less than 2 dB - but it was impossible to measure it accurately with the equipment available.

Such evaluation by comparison is not, of course, an adequate substitute for absolute measurements but will, nevertheless, give those who intend to build and use the integrated system an idea of the results they can expect. This was affirmed by having the prototype handed 'on probation' to eight experimenters for use in their own house: seven users preferred the integrated indoor aerial to their existing central antenna system. M

M. W. M. Henst

Homemade Display

In many applications where seven-segment displays are used, such as digital clocks, it is desirable to have larger characters than the 0.3" displays commonly available. Large displays are, unfortunately, expensive. This article describes a simple method of constructing a 'home-brew' display with 40 mm (approx 1½ in) characters.

The display described here uses filament lamps as the source of illumination. At first sight this would seem to be inviting rapid failure of the display, since a 4-digit display uses 28 lamps, with consequently 28 times the chance of failure of a single lamp. This, however, is not the case.

A 6 V 50 mA bulb has a life of typically 500 hours. This does not seem very promising, but if the supply voltage is reduced then the life increases as the 13th power of the ratio of the nominal to the actual voltage i.e.

Life at reduced voltage

$$T_a = \left(\frac{V_n}{V_a}\right)^{13} \times T_n$$

Thus if a 6 V bulb is operated on a 4 V supply the expected life will be

$$\left(\frac{6}{4}\right)^{13} \times 500 = 100,000 \text{ hours.}$$

The brightness of the lamp at 4 V is still quite adequate for use in the display, and the lamp also runs considerably cooler, which must also be considered when so many lamps are used in a confined space.

The display consists of four main components, a window mask (optional), which in the case of the clock display separates the minutes from the hours, two further masks with slots cut in the display format, and a backplate on which the lamps are mounted.

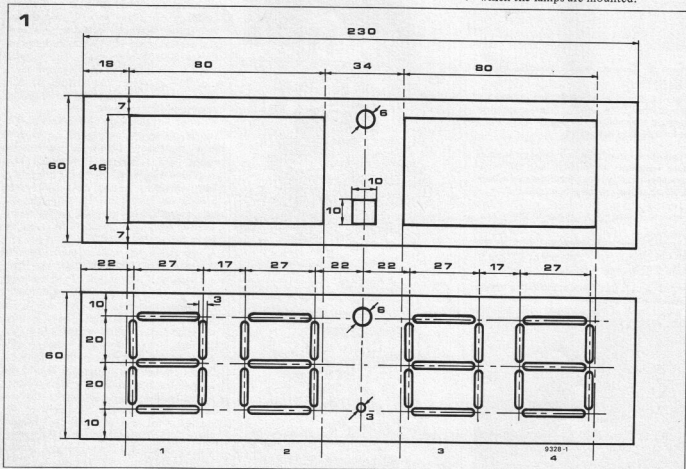

How to make a display

Figure 1. Dimensions of the masks (in mm). One window mask (upper) and two segment masks (lower) are required. Mounting holes are not shown, as these will depend on the case to be used.

Figure 2. The lampholders consist of wire wrapped round the threaded cap of the lamp. Plastic conduit is molded to provide a 'light-pipe' and glued to the back of one of the segment masks. If desired, a diffuser and/or filter can be sandwiched between this mask and the second segment mask.

Figure 3. The lamps can not be driven direct from the output of a 7447, so driver transistors must be added. The emitters are connected to the positive supply rail (figure 4). If the circuit is run direct from a 5 Volt TTL supply instead of the circuit of figure 4, a 2 Amp reset diode should be added in the positive supply rail to the display.

Figure 4. The power supply with light-controlled output voltage for automatic display brightness control.

The masks are shown in figure 1. The layout shown is for a digital clock, but could easily be adapted for other digital instruments. The choice of materials is up to the constructor, but bear in mind that they should be easy to work and have a good appearance. A suitable choice is epoxy-glass printed circuit laminate, preferably with the copper etched away, which can be cut very easily with a hacksaw and may be sprayed matt black to give an attractive appearance.

The first step in the construction is to make the masks by drilling and filing the holes and slots to the pattern in figure 1. The two segment masks can be clamped together during these operations to ensure exact alignment of the holes. The bulb which is to illuminate a particular segment is (obviously) placed behind the corresponding slot in the mask. However, to prevent light 'leaking' to the adjacent segments a 'light-pipe' must be provided for each lamp, as shown in figure 2. These are made from 16 mm (5/8 in) plastic electrical conduit, cut into 30 mm (1.2 in) lengths. One end of this is left circular, to accommodate the bulb, and the other end is flattened to the shape of the display segments.

To accomplish this a wooden template must be made having the same end cross-section as a display segment. The end of the conduit is then softened in boiling water or over a hotplate, the ends are pinched together (wear gloves!) and the template is inserted to maintain the correct shape until the plastic cools. The conduit for the decimal point bulb (if used) between the hours and minutes need not be flattened.

The template also comes in useful during the fixing of the conduit to the back of the mask. The template is poked through the slots in the mask and the pieces of conduit can be slid over the end of it to ensure perfect alignment. The pieces of conduit should be fixed in place using an epoxy adhesive such as 'Araldite'. The backplate of the display can be

made of a sheet of epoxy-glass copper laminate circuit board. Holes are drilled in it in each position where a lamp is to be mounted, large enough for the body of the lamp to pass through. Lampholders are made from 18 or 20 S.W.G. tinned copper wire, by winding it around the threads of the lamp. The lampholders can then be soldered in place over each hole in the backplate, and the lamps screwed in so that the end cap of each lamp protrudes through the backplate. The copper coating of the backplate provides the common connection for the lamps and individual wires can be soldered to the end caps of the lamps (see figure 2).

When the backplate is offered up to the mask each lamp should slide into its piece of conduit. Any slight misalignment will be taken up by the springiness of the lampholders.

Lamp Drivers

As each lamp will take some 33 mA at 4 V it is not possible to drive the lamps direct from a TTL decoder such as the 7447, so driver transistors must be used as in figure 3. The inputs to these are connected to the outputs of the 7447. 28 TUP's are required for a four-digit display.

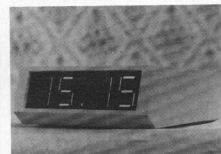
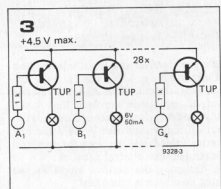
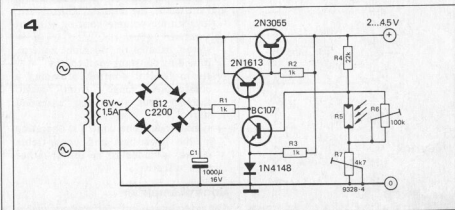
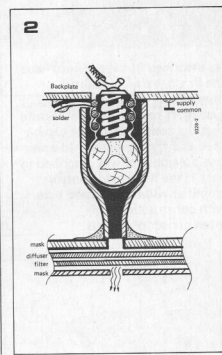

Figure 4 shows the circuit of a power supply with light-controlled output voltage for automatic display brightness control to suit ambient lighting. If the ambient light level is high then the resistance of the LDR R5 will be low and the output voltage will rise to keep the base voltage of the BC107 constant. The display brightness will thus increase. If the ambient light level is low the resistance of R5 will be high and the output voltage will fall. R5 is mounted so that it protrudes through a hole in the window mask, and can sense the ambient light falling on the display.

Finishing Touches

So that the filaments of the lamps cannot be seen a diffuser screen of translucent material must be placed between the two segment masks. This may be a sheet of ground or opal glass, acrylic sheet or just plain white paper. A coloured filter of acrylic sheet or celluloid can also be sandwiched between the two masks. The front mask can be sprayed with matt black paint to enhance the display contrast.

As a final hint, to obtain more even illumination, the inside of the conduit may be painted with aluminium paint to reflect the light.





As described in the previous issue, the Preco is a high quality preamplifier/control amplifier system. It has the unusual feature that the control amplifier can be used as a remote hand-held unit. The preamplifier was described in part 1; the hand-held control amplifier will be discussed here, with construction and interconnection details.

The preamplifier and input selector unit (Elektor 12, p.416) has a low impedance output. The signal level and output impedance are such that it can drive a fairly long screened cable without difficulty, and also provide the low source impedance required for driving a Baxandall tone control network.

In designing the control amplifier, we must now bear in mind that:

- the source impedance will be low, and a known value. This is useful.
- the output will have to run over a 'phantom' power supply, for economy of connecting cable as discussed in part 1. This is a complication.
- the unit must be fairly small, for use in an attractive hand-held box. This restricts the number of bulky components (e.g. electrolytics) that can be used.

Assuming that the control amplifier functions should be musically-useful and sufficient, the required controls are:

- logarithmic volume control, without 'contour'
- stereo balance or 'position' control, providing constant total energy;
- stereo 'width' control, providing a continuous range from mono through 'true stereo' to 'extended stereo';
- symmetrical tone controls, operating in the lower-bass and upper-treble ranges, intended to be useful rather than 'effective'.

Control amplifier

The complete circuit for one channel is

Table 1. Performance figures.

Preamp

Output level: 190 mV (nominal)
4.5 V (maximum)

Input sensitivity:

Input 1: 40 ... 1500 mV*

Input 2: 0.5 ... 1500 mV*

Input 3: 1.25 ... 9 mV*

* can be preset for each input, see text and table 2.

Control amplifier

Output level: 400 mV (nominal)
1 V (maximum)

Input sensitivity: 190 mV (nominal)

Treble control: ± 10 dB at 12.5 kHz

Bass control: ± 12.5 dB at 63 Hz

Preco, overall

Distortion: ≤ 0.1 % at 1 V out
 ≤ 0.03 % at 400 mV out

Signal-to-noise ratio:

disc input: > 95 dB

other inputs: > 100 dB

Maximum cable length to remote control unit: 30 ft.

T. Meyrick

part 2

Figure 1. Complete circuit diagram (one channel shown). Figure 1a is the preamp/input selector, figure 1b is the control amplifier.

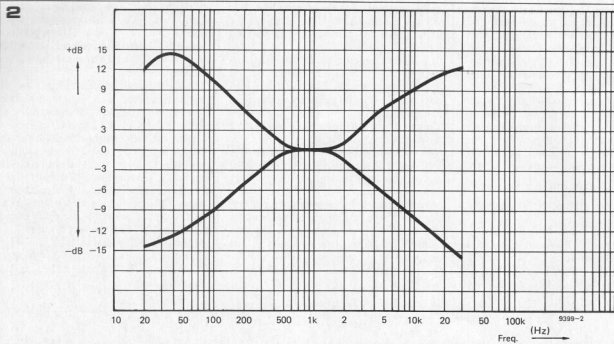

The next step is to convert this remote gain stage into a control amplifier.

Tone control

The tone control circuit is basically that suggested by P.J. Baxandall, which has since become something of a world standard (and rightly so!). This particular variant is similar to that employed in the Quad 33 control amplifier. It has the advantage of securing a better noise-match to an amplifier using bipolar transistors, provided it is driven from a low-impedance source. This is the reason why the preamplifier was designed for a low output impedance, and why the volume control is a 1 k potentiometer.

The principle of the bass control is fairly well known. The associated amplifier works in the 'virtual earth' configuration, whereby the input impedance and the feedback impedance both rise with decreasing frequency. In the centre position of the bass control, both impedances track in such a way that the net gain (determined by the ratio of these impedances) is constant — the frequency response is 'flat'. When the bass control is set to an off-centre position, the two impedances no longer track correctly: one or other of them dominates at lower frequencies, causing an increase or decrease of gain in this range — bass boost or cut, respectively. The result is shown in figure 2.

A treble control function is now basically obtained by shunting RC networks across the two 18 k resistors (R31 and R32). This causes both the input and the feedback impedances to fall in value towards higher frequencies. Once again, a symmetrical fall has no effect, but this symmetry is thrown out of balance when the treble control is set off-centre — causing treble boost or cut (see figure 2).

The favourable noise-match provided by this circuit results from the direct con-

3

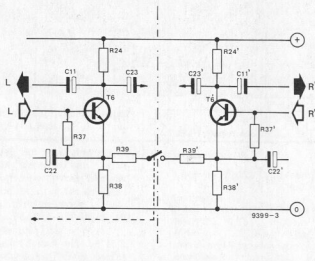

nection between the virtual earth point (the slider of P3) and the base of T5. The amplifier is thus driven from a low-impedance source: the 18 k resistor divided by the open-loop gain, i.e. about 600 Ω .

Balance control

The balance (or 'stereo position') control P5 operates in a slightly unusual way.

For AC, T6 operates as a current source: the current 'coming out' is determined by the signal voltage at the emitter of this transistor and the impedance between the emitter and supply common (R38, mainly).

The output signal at the collector of T6 (this is also the actual output of the Preco) is simply the product of the collector current of T6 and the load impedance at this point. P5 can be used to vary this load impedance, so the position of the slider will determine the gain-ratio between the two channels.

The control range is from about +3 dB

to -8 dB for each channel, and the tracking is such that the total reproduced power level is reasonably independent of the setting of P5. Note that this circuit can be readily extended to surround-sound operation with more than two loudspeaker channels!

Width control

One of the most uncommon, least understood and most controversial controls is the 'stereo image width control'. However, experience shows that it can be a useful feature, and it can be achieved with one resistor and one potentiometer...

The principle can be explained in several ways. In the article 'Tap preamp' (Elektor 4, p. 624), the discussion was based on 'seeing what happens to the original left and right input signals'. Elsewhere in this issue an explanation is given that is based on a mechanical equivalent using weights and balloons on a balance. A third possible explanation will be given here.

Table 2

R1,R1'	R2,R2'	R3,R3'	R4,R4'	R14,R14'	input sensitivity	
					input 1	input 2
100 k	4k7	100 k	4k7	∞	880 mV	880 mV
100 k	10 k	100 k	10 k	∞	440 mV	440 mV
100 k	22 k	100 k	22 k	∞	220 mV	220 mV
56 k	56 k	56 k	56 k	∞	80 mV	80 mV
0	100 k	0	100 k	∞	40 mV	40 mV
-	-	0	3k3	3k3	-	5 mV

Figure 2. Tone control characteristics (extreme positions of the controls).

Figure 3. Detail of the width control circuit.

Figure 4. Printed circuit board and component layout for the preamplifier (EPS 9398).

Table 2. Resistor values for various input sensitivities.

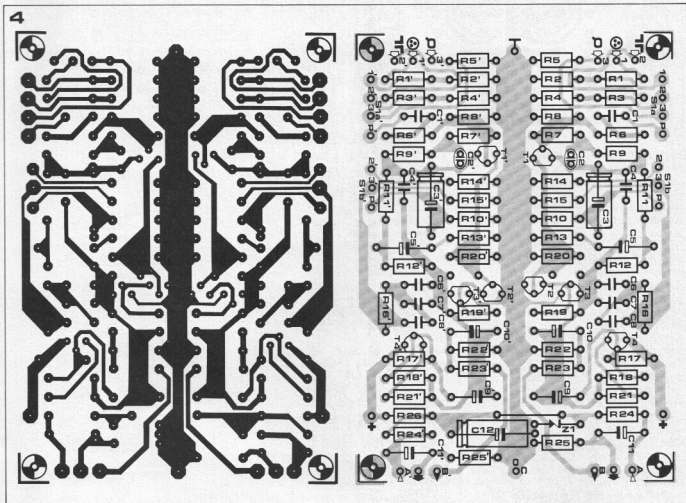

Any stereo signal pair can be considered as the sum and difference of a monophonic 'M' signal and a left-right difference signal 'S'. In stereo broadcasting it is the 'S' signal that is modulated on the 38 kHz subcarrier; with gramophone records the 'M' and 'S' signals correspond to horizontal and vertical modulation of the groove, respectively.

It is generally assumed that professional mixing and balancing is done by an operator seated at the third point of an equilateral triangle with reference to his monitoring loudspeakers. If, for any reason, this was not in fact the case — or if the home listener wishes to sit in some other position of symmetry relative to his loudspeakers — it may be possible to improve the resulting stereo image by slightly modifying the relative gain of the 'S' signal path.

In the control unit, P2 is the 'relative gain' control. It has no effect on the 'M' signal, because this is (per definition!) in phase and at equal amplitude in both channels. The 'S' signal, on the other

Parts list for figure 4:

Resistors:	R25, R25' = 27 k
R1, R1' = (1)	R26 = 680 Ω
R2, R2' = (1)	
R3, R3' = (1)	(1) see table 2
R4, R4' = (1)	(2) preferably metal film
R5, R5' = 56 k	
R6, R6' = 1 k	Capacitors:
R7, R7' = 33 Ω	C1, C1' = 220 n
R8, R8' = 470 k (2)	C2, C2' = 470 p
R9, R9' = 100 k (2)	C3, C3' = 100 μ /16 V
R10, R10' = 68 k	C4, C4' = 27 p
R11, R11' = 15 k (2)	C5, C5' = 10 μ /16 V
R12, R12' = 68 k (2)	C6, C6', C7, C7' = 12 n (5%)
R13, R13' = 22 k	C8, C8' = 8n2 (5%)
R14, R14' = (1)	C9, C9' = 220 μ /4 V
R15, R15' = 270 Ω	C10, C10', C11, C11' = 10 μ /25 V
R16, R16' = 10 k	C12 = 100 μ /25 V
R17, R17' = 33 k	
R18, R18' = 3k9	Semiconductors:
R19, R19' = 2k7	T1, T1', T3, T3' = BC 179C or equ.
R20, R20' = 5k6 (2)	T2, T2', T4, T4' = BC 109C or equ.
R21, R21' = 100 Ω	Z1 = zener diode 18 volt 400 mW
R22, R22' = 100 k	
R23, R23' = 100 Ω	Sundries:
R24, R24' = 3k3	S1a/S1b/S1a'/S1b' = 3-way, 4-deck

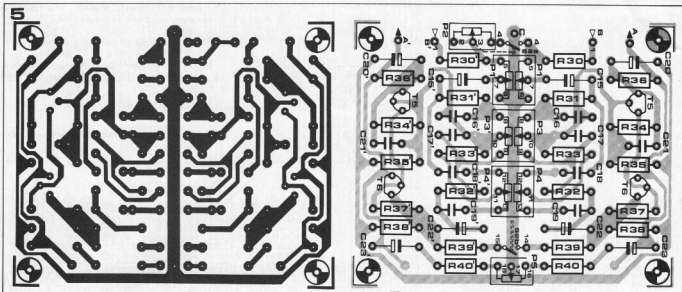

hand, is at equal amplitude but in anti-phase in both channels. The potentiometer therefore introduces crosstalk ('blend') between the two channels which reduces the level of the 'S' signal. At one extreme end of the control range the resistance of the potentiometer is zero, causing infinite crosstalk and therefore zero 'S' signal. The result is mono — only the 'M' signal is left. At the other extreme end of the range, P2 is simply a 10 k resistor; the crosstalk is now reduced to approximately -30 dB, so the 'S' signal is scarcely attenuated. So far so good, but the control range is now from mono to not-quite stereo. The next step is to offset the control range so that 'normal separation' (i.e. 'true stereo') corresponds to the mid-position of P2. This is achieved by adding R39 and R39' between the emitters of T6 and T6' (see figure 3). In effect, this converts the output stage into a differential amplifier: the reduced impedance between the emitters boosts the output currents for differential-mode signals (the 'S' signal) but has no influence on the common-mode signal (the 'M' signal). The resistor values are chosen so that the relative boost of the gain for the 'S' signals at the output is equal to the relative attenuation of these signals caused by P2 at the input, when this control is set in the mid-position.

The 'S' level can now be set anywhere between complete suppression (mono) and 3 dB boost relative to the 'M' level (extended stereo); the mid-position of P2 corresponds to equal 'S' and 'M' levels (stereo).

People who have a (subconscious?) distrust of any system that 'fiddles with the channel separation' in a stereo system can add S2: it defeats the entire control and switches the amplifier to stereo.

Note that R23 and R30 form part of the 'blend' circuit — they would be needed in any case if a 'mono' switch were to be included. This does mean, however, that the output at 'B' will not normally have full channel separation unless switch S2 is opened — a point to watch if this output is to be used for tape recording! It would be safer in that case to replace R23 by a wire link and change the value of R30 to 390 Ω .

Interconnections

Basically, interconnecting the preamplifier and the control amplifier is quite simple: Connection 'A' on the preamp is linked to 'A' on the control amp, 'B' is linked to 'B', 'C' to 'C', etc. In total, four signal lines and a supply common connection are required.

Unfortunately, in the readily-available type of four-core screened cable the actual cores are individually screened —

Parts list for figure 5.

Resistors:
 R30, R30' — 270 Ω
 R31, R31', R32, R32' — 18 k
 R33, R33' — 3k3
 R34, R34' — 56 k
 R35, R35' — 470 k
 R36, R36' — 12 k
 R37, R37' — 4k7
 R38, R38' — 330 Ω
 R39, R39' — 560 Ω
 R40, R40' — 390 Ω

Potentiometers:
 P1, P1' — 1 k log stereo
 P2 — 10 k log
 P3, P3' — 100 k lin stereo
 P4, P4' — 10 k lin stereo
 P 5 = 2k2 lin

Capacitors:
 C15, C15', C22, C22' = 1 μ /12 V
 C16, C16', C17, C17' = 22 n
 C18, C18', C19, C19' = 8n2
 C20, C20', C23, C23' = 10 μ /12 V
 C21, C21' = 1n5

Semiconductors:
 T5, T5' = BC 179C or equ.
 T6, T6' = BC 109C or equ.

Sundries:
 S2a/S2b double-pole single throw

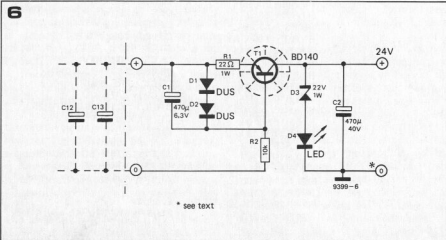

* see text

Figure 5. Printed circuit board and component layout for the control amplifier (EPS 9399).

Figure 6. A possible circuit for deriving the supply to the Preco from the power amplifier supply.

Figure 7. Complete interconnection diagram, showing where the screens of the various cables are connected to each other and to supply common.

7

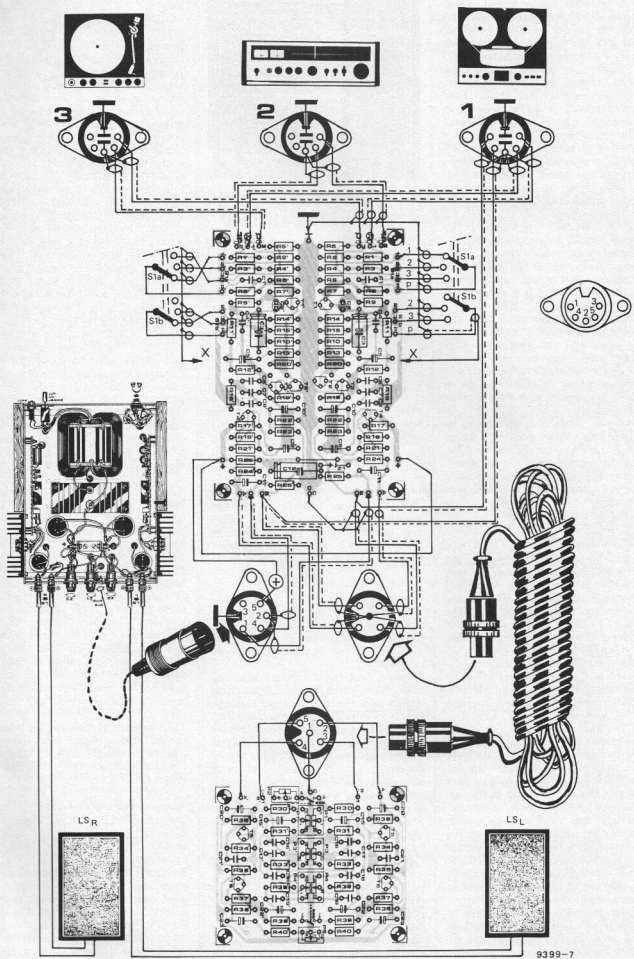

but there is no 'signal return' other than the common interleaved screen. Manufacturers have presumably made this choice for reasons of cost — without realising the RF implications of a screen that is used to carry signal currents.

The problem is that any HF voltage induced between the ends of the screen, for instance by a broadcast or 'ham' transmitter, will be delivered direct to the amplifier input — and this can lead to distortion and a variety of nasty demodulation effects ('breakthrough').

This can be avoided only by providing a separate signal return inside the screen, and connecting the screen itself to supply common at one end only.

Some people have known all this for years — and studio wiring is always fully screened (if only to avoid mains hum!).

The question is: which is cheaper, doing the job properly by 'killing' the aerial — or inserting chokes and capacitors all over the circuit to kill the unwanted signals?

The control unit described here was designed to tolerate a moderate RF input signal level, so standard four-core screened cable can be used in most cases. In the unlikely event that trouble is encountered, a 4n7 capacitor can be included in parallel with P1 (between points 5 and 6).

If the power amplifier is embarrassed by HF (and one cannot suitably redesign it), a 1 k resistor can be included between the preco output and the power amplifier input, and a 2n2 capacitor connected across the power amplifier input.

Construction details

The p.c. board and component layout for the preamplifier/input selector unit are shown in figure 4; the board and component layout for the control amplifier are given in figure 5. The values of resistors R1, R2, R3, R4 and R14 depend on the required input sensitivities (see table 2).

As discussed earlier, both units can be mounted in the same cabinet to obtain a conventional preamp/control amp unit. Alternatively, the control amplifier can be used as a 'remote' hand-held unit.

In either case it is advisable to keep the mains transformer well out of the way, and a simple solution is to tap the preamplifier supply off from the power amplifier. The circuit shown in figure 6 can be used for this purpose. In essence, T1 simply acts as a current source, effectively preventing the ripple on the main amplifier's power supply getting through to the preamp; the zener diode and LED stabilise the output at about 24 V. The circuit should be mounted in the main amplifier case.

Particular attention should be given to the supply common connection (or lack of it!) in figure 6. The 'input' supply common connection is connected to the main supply electrolytics, whereas the 'output' supply common is connected at the input to the main amplifier.

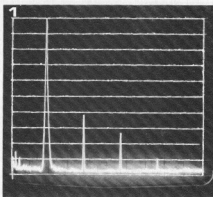

Table 3. Test voltages.

Test point	voltage ($\pm 20\%$)
1	2.5 V
2	3 V
3	0.6 V
4	11.5 V
5	12 V
6	13 V
7	4.5 V
8	5 V
9	1.5 V
10	1 V
11	7.5 V

Table 3. Test voltages measured at the points shown in figure 1.

Taking the most complicated arrangement as an example (preamp, control amp and main amp as three separate units), figure 7 shows an 'approved' wiring layout. The main points to watch are:

Input connections

The signal inputs are connected to the preamp using screened cable. The 5-pin, 180° DIN plugs shown are probably the worst type of connectors to wire correctly . . .

However, the basic principle is as follows. The screen of the input leads should be connected to supply common at the preamplifier input; the outer shell of the socket should also be connected to supply common; the incoming signal return must also be connected to supply common; if the incoming cables are of an appreciable length, using the outer screen as signal return should be avoided if possible; earth loops must be avoided. Starting from the signal source (e.g. disc cartridge), the 'ideal' connection would be: the two 'hot' connections and the two signal returns each run over a separate core inside the outer screening of the cable; the screen itself is only connected to supply common at one end (at the preamp). This is where four-core screened cable is useful! In practice, regrettably, most manufacturers supply two-core screened cable with their equipment and use the screen as common signal return. No matter what type of cable is used, however, the DIN

norm specifies that pins 3 and 5 of the plug are the left and right signal connections, respectively, and pin 2 is supply common. This means that the screen and any additional signal return cores are all connected to this pin. Of course, if one is not particularly worried about being 'conventional', there is no reason why the separate signal return cores should not be connected to the unused pins 1 and 4. They can then continue as separate cores right up to the preamp board, where they are connected to supply common.

Going back to the 'official' version, however: we now have two signal lines and one supply common connection on the socket. An additional complication is that the metal outer shell of the socket and of the plug must also be connected to supply common. The best solution is usually to connect the outer shell of the socket to chassis, as shown — note that it is *not* connected to pin 2!

In practice, a small capacitor (10 n or so) between the shell and pin 2 has been known to kill some of the unwanted RFI. The cable manufacturers once again make life difficult at this point: the metal outer shell of the plug is often connected to pin 2 inside the plug. Sometimes it is possible to get at this connection and cut it. If the plug is molded on to the cable, the only really effective solution (apart from investing in a new plug) is to insulate the outer shell of the socket from chassis: it will be connected to supply common as soon as the offending plug is inserted. Perhaps all this may sound rather 'perfectionistic' . . . However, practical experience does show that these problems occur more often than one might expect. A simple test can illustrate this. It often happens that a preamp is 'dead silent' as long as no inputs are connected; as soon as a cable is plugged in it starts to hum. This is usually due to the problems outlined above. To test whether this is the case, turn the volume and bass controls up and then short pin 2 to the outer shell of the input socket. If the hum increases, you will need to use plugs without an internal connection between pin 2 and the outer shell . . .

The connections from the input sockets to the preamp board should now be relatively straightforward: the only thing to watch is that earth loops are avoided.

Preamp/control amp connection

The problems involved here have already been discussed. The only new element involved in figure 7 is the type of connector.

To eliminate the possibility of putting plugs into the wrong sockets, it is a good idea to use different types of socket for the various jobs. The inputs are 180° DIN, so the interconnecting cable will have to use something else. The five-pin 'die' plug shown in figure 7 has one disadvantage: the plug fits the socket in two different ways — pin 4, say, of the plug can go into pin 4 or

pin 2 of the socket. In most of the connections this could have disastrous results, but in the interconnection between preamp and control amp the danger is slight. The only thing that will go wrong if the plug is inserted 'the wrong way round' is that the stereo balance control will work 'back to front'.

Preco to power amplifier

As described earlier, it is advisable to derive the supply to the Preco from the power amplifier supply, if possible.

For similar reasons to those outlined earlier, the preferred arrangement is to use four-core screened cable: two cores for the left and right signal outputs, one for positive supply and one for supply common. The screen is then connected to supply common at one end only.

The connector suggested in this case is a 5-pin, 270° DIN plug. If desired, pin 3 on this connector can be used for the supply common connection: an extra lead would then run from this point to the supply common connection on the preamplifier board; pin 2 would be used for the connection to the screens only.

Tape recorder

The best point to use as an output for recording on tape is the output of the preamp. This is shown in figure 7, input 1.

The only point to watch here is that the width control must be switched out of circuit when recording. Alternatively, R23 and R23' can be replaced by a wire link and R30 and R30' can be increased to 390 Ω.

Final comments

The performance figures are summarised in table 1. Photo 1 shows the measurement results on a spectrum analyser, test signal 1 kHz, vertical scale 10 dB/div, horizontal scale 500 Hz/div. Reference signal level (0 dB) was approximately 775 mV. As can be seen from the photo, distortion was more than 60 dB down, i.e. less than 0.1%. The residual noise on the photo is the spectrum analyser: a separate measurement shows that the signal-to-noise ratio of the Preco is better than 105 dB.

At a lower reference level (-10 dB, or about 250 mV), distortion proved to be approximately -70 dB (0.03%), and the signal-to-noise ratio was about 100 dB. Finally, should any problems occur, table 3 shows the voltages measured at the various test points marked in figure 1. This table can be used as an aid when trouble-shooting - bearing in mind that voltages within 20% of the values given can be considered 'correct'.

image width control

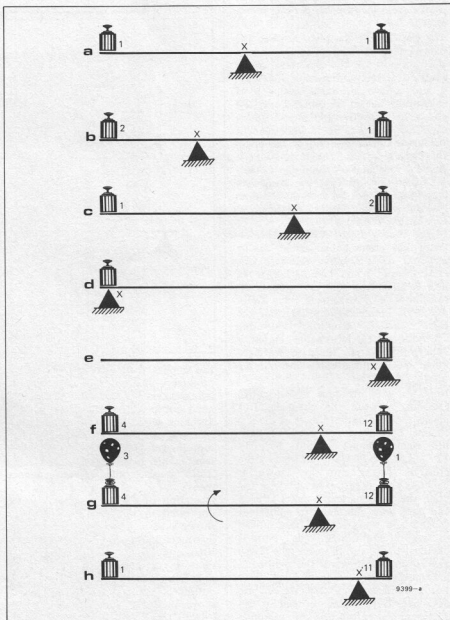

One of the least understood controls on an amplifier is the 'stereo image width control'. From several readers' queries it has become obvious that a new attempt to explain it in an entirely different way should be quite welcome.

In this short article, the explanation is based on comparison with an analogous mechanical system: weights, balloons and a balance.

In figure a, two equal weights (say, 1 kilogram) are placed at the ends of the

balance. The balance itself is considered weightless. For equilibrium, the pivot (X) must be at the centre of the balance.

If an extra kilogram is added to the weight at the left, the pivot must be moved to a position left of centre to restore equilibrium (figure b). Similarly, if an extra weight is added at the right instead, the pivot must be moved out towards the right (figure c).

If there is no weight at all at one end, the pivot must be placed under the remaining weight — the balance itself is weightless! — as shown in figures d and e.

A stereo loudspeaker pair works in a similar way! Assume that the position of the loudspeakers corresponds to that of the two weights at the end of the balance; the 'weight' corresponds to the sound level at the speaker — assuming for the moment that only one signal source (solo instrument) is being reproduced.

The position of the pivot X when the balance is in equilibrium corresponds to the position of the phantom sound source in stereo reproduction. Figures a, d and e give an exact analogon of (phantom) images at centre-front, left and right respectively; figures b and c can only be taken as an indication of the approximate position of the phantom stereo images. The main point is that the mechanical system can be used to study the influence of changes in amplitude balance between the channels ('weight') on the position of the phantom image ('pivot').

It has already been shown mathematically that 'stereo enhancement' can be achieved using negative crosstalk (see 'TAP preamp 2' and 'Preco 2'). This can now be illustrated using the balance.

Imagine a solo instrument being reproduced via a stereo loudspeaker pair, the right channel amplifier delivering 12 Watts and the left channel amplifier delivering 4 Watts. Translate Watts to kilograms and the result is shown in figure f.

Now we will introduce 25% negative crosstalk between the channels. This means that the output power of the left channel becomes $4 - \frac{1}{4} \times 12 = 1$ Watt; the right channel output becomes $12 - \frac{1}{4} \times 4 = 11$ Watts. In figure g the crosstalk components are shown as balloons (i.e. negative weights); in figure h the balloons and weights at each end have been combined to equivalent weights and the pivot has been moved to restore equilibrium. The result is obvious: the phantom image (the pivot) has moved out towards the right-hand loudspeaker.

For a more extreme case, we can use 50% negative crosstalk instead of the 25% assumed in the previous example. The corresponding balloons are shown in figure i; the final situation is shown in figure j. In this case, the resulting 'weight' at the left is actually a balloon; the pivot has to be moved out past the weight at the right to restore equilibrium. In the case of stereo localisation,

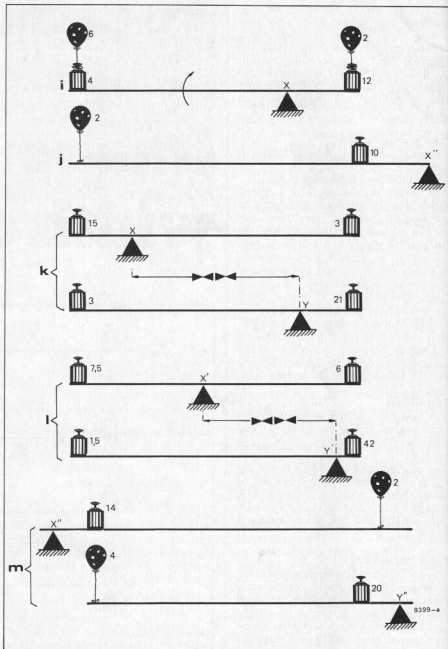

this implies that negative crosstalk can produce a phantom image 'outside' the loudspeakers (to the right of the right-hand loudspeaker, in this case)!

Speaking generally, introducing negative crosstalk can shift all 'off-centre' phantom images further out from centre-front. This increase in 'stereo image width' is also called 'stereo enhancement'.

Operation of a balance control can be illustrated in the same way. Figure k shows a basic situation with two solo instruments X and Y. Assume that the balance control is now turned to the right, so that the output level of the right-hand channel is doubled and the output at the left is halved. Figure l shows the result: both phantom images ('pivots') move out to the right and the stereo image width is reduced.

To further illustrate the difference between a balance control and an image width control, we can go back to the situation in figure k and use the image width control to introduce 33% negative crosstalk. The result is shown in fig-

ure m: both pivots move out from the centre (past the speakers, in this case) — increasing the image 'width' but without altering the 'balance'.

equin

The first part of this article (Elektor 12, p. 448) outlined the thinking that led to the Equin amplifier design.

In this second part of the article, the 'paper' amplifier is converted into a ready-to-build recipe.

To what extent the performance of the prototype will be equalled by other 'cooks' depends partly on the quality of the components used. However, the intention was to produce a 'musical' amplifier — and the listener's ear shall be the final judge. In our experience even a 'worst-case' amplifier could not be distinguished by ear from the prototype.

2

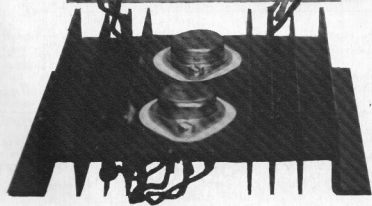
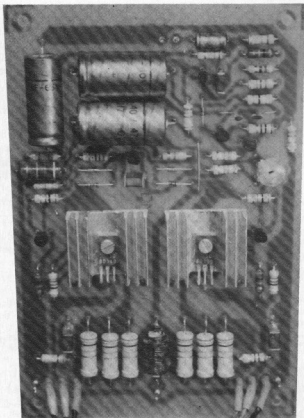

First of all, a little more about component quality. It should be obvious that even the most carefully designed circuit, when built up with parts of indifferent quality, will quite probably give an indifferent result.

Higher quality, on the other hand, invariably means 'higher price'. This implies that unnecessarily high quality will mean unnecessarily high price. A design's success may not therefore depend upon the use of precision R's and C's, or upon carefully-matched transistor-pairs. With the few exceptions about to be mentioned, all parts can be of readily-available 'standard quality' — midway between junkbox and laboratory-standard!

The first warning concerns the loud-speaker-coupling electrolytic, C10. This must be a reliable type, of adequate rating. Its rated working voltage should be at least equal to the maximum supply voltage. It should have a ripple-current rating at least equal to the maximum output current; if that means a bulky component use a bulky component — anything else might cost a lot of cash later! The specified value of 2000 to 2500 μF is more than large enough, even for the case of a 4 Ω load (forget the nonsense about extremely high damping factors at extremely low frequencies...).

The second warning concerns the use of bargain-variety 2N3055 transistors of undisclosed origin. (T7 and T10.) Some of these 'workhorses of electronics' have excessively high leakage currents, that often increase with operating time. Suppliers have been known to stamp 2N3055 on the unmarked case of a quite different animal (that had a much smaller crystal into the 'bargain').

Still on the subject of output transistors, it will help if the devices used have a reasonably high current gain — since this will reduce the dissipation in the drivers (T6 and T9).

The cutoff-frequency of the output transistors is important, since it has a bearing on the switching behaviour of the output stage at high drive levels and

higher frequencies. Assuming a symmetrical drive signal, 'perfect' output transistors in class B conduct in turn, each for just over 50% of the time. Real transistors however have finite turn-on and turn-off times, so that there will be an interval between the polarity-reversal of the drive-signal and the actual moment at which the conducting transistor turns off. This effect reduces the output stage efficiency at higher frequencies, i.e. the dissipation will increase.

The higher the cutoff frequency (f_T , also called 'gain-bandwidth product') of T7 and T10, the better (faster) these transistors will switch. On the list of 'possible types' for T7 and T10 it is the 2N3055 that has by far the lowest f_T . It is also the lowest in price. It would be theoretically 'better' to use considerably faster devices, with a gain-bandwidth product of 50...100 MHz. The trouble is that such transistors are not only expensive; their construction is necessarily 'delicate' — so that momentary overloads can easily destroy them. The Equin is not provided with the complicated and expensive limiter circuitry that would be needed to prevent this. On the other hand, transistors of the 2N3055 family are much more ruggedly constructed and not so easy to destroy!

The emitter resistors R19 and R23 should be built up with three one-watt carbon film resistors in parallel. This arrangement is a) cheaper, b) non-inductive — and any inductance in the output stage would make the switching performance even worse. Note that low-value 'carbon resistors' by some makers

Table 1. Specifications.

Continuous sinewave power, both channels driven, at an off-load supply voltage of 45 volts:

2 x 20 watts into 8 ohms

2 x 35 watts into 4 ohms

Ditto, but at an off-load supply voltage of 60 volts:

2 x 35 watts into 8 ohms

2 x 50 watts into 4 ohms

(These minimum-ratings allow for a 'typical' on-load drop in the actual supply voltage).

Harmonic distortion:

< 0.1% peak at 1 kHz

Input impedance:

approx. 40 k Ω

Input sensitivity:

580 mV (RMS nom.) for 20 W into 8 ohm

550 mV (RMS nom.) for 35 W into 4 ohm

760 mV (RMS nom.) for 35 W into 8 ohm

730 mV (RMS nom.) for 50 W into 4 ohm

Figure 1. Circuit diagram of the Equin power amplifier. This diagram differs from that given in part 1, to the extent that a few parts have been added or changed in value. D5/R27 improves the clipping-behaviour on negative overdrive. L1/R28 may be added to improve impulse-response when using electrostatic loudspeakers.

Figure 2. The Equin power supply does not need regulation! This figure also shows the compulsory supply and supply common wiring for a stereo-pair; the central 'common' point (C12, C13) is only to be connected to chassis via the poweramp p.c. boards, at their common input.

(e.g. Mullard) are in fact metal-film types, that will double as fuses in the event of short-circuits. The same applies to R15, if the collector of either T7 or T10 is shorted to the heatsink.

The list of alternative types given for transistors T1 to T10 is by no means exhaustive. When a given type is available with a suffix a, b or c denoting a current-gain selection, do not use the 'basic' version; this product is often the cheapest, because it consists of the ultra-low-gain 'leftovers'. With the exception of T1 and T4, all transistors should have a V_{CEO} rating at least equal to the supply voltage.

The output power

The output power rating of an amplifier is admittedly important, but invariably gets too much attention. Nonetheless, to please the greatest possible number of constructors, this article will indicate how the standard 45-volt-supply version can be modified for uprated operation on 60 volts.

Table 1 specifies the continuous sinewave power that the amplifier will deliver into two load impedances at each of two nominal supply voltages. These ratings are essentially 'worst case' values; the actual power obtained will depend on the quality of the supply components.

Table 2 gives information on the power transformer that will be required. The load currents given apply to sinewave output, both channels fully driven. Since a music signal invariably has a lower average power than a sinewave of the same peak value, the music load-current will be lower than the values

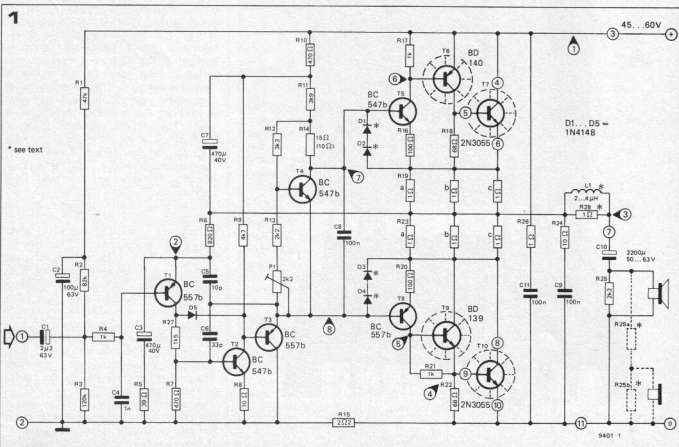

Z1 = 2 A
Z2, Z3 = 6.3 A
C12, C13 = 4700 μ /63 V
D₁, D₂ = 10 A/100 V

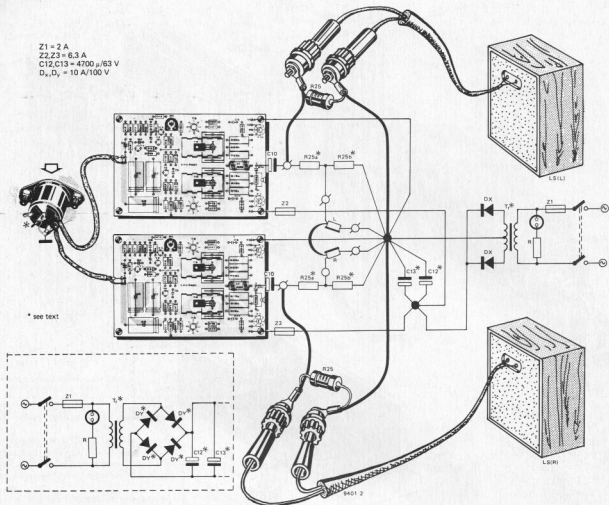

Table 2.

Mains-transformer requirements, standard version.

Nominal DC voltage (volt)	45
Secondary AC (off-load) voltage (volt)	36 or 2 x 36*)
Average (direct) current at table 1	2x 20 W/8 Ω : 1.6 A
power level (both channels driven)	2x 35 W/4 Ω : 3 A

*) centre-tapped winding for two-diode rectifier.

Mains-transformer requirements, uprated version.

Nominal DC voltage (volt)	60
Secondary AC (off-load) voltage (volt)	45 or 2 x 45*)
	(maximum 48 or 2x48)
Average (direct) current at table 1	2x 35 W/8 Ω : 2.1 A
power levels (both channels driven)	2x 50 W/4 Ω : 3.6 A

*) centre-tapped winding for two-diode rectifier.

given. If the power transformer has a very low winding resistance the supply voltage will not drop so far on continuous load. The continuous output power and the current drawn will then both be higher than the values given in tables 1 and 2.

When the 60 volt version drives a 4 ohm load, the current limiting diodes D1...D4 will slightly reduce the maximum output power. Anybody who proposes for this reason to omit the diodes should note that the only short-circuit protection left will be the fuses Z2 and Z3!

The amount of ripple on the loaded supply line depends on the components used. If one has an oscilloscope it is permissible to trim R1 for symmetrical 'clipping' of the output waveform (mid-point voltage exactly halfway between chassis and ripple-trough levels). Watt was that about people giving too much attention to output power ratings?

The printed circuit board

The circuit and the pc board layout have both been deliberately designed to allow the use of several alternative transistor types.

The drivers T6 and T9 may be TO5 types (with cooling multifin), or TO5 types - with - welded - on - cooling - plate

(40410 and 40409 respectively). The popular flat-package BD137...140 series can also be used, with the copper pad in contact with a U-shape heat sink (see figure 3b).

All other transistors are either TO5 types or 'plastics' with their base-lead in the middle.

It is a clever idea, when assembling the amplifier, to turn P1 fully anticlockwise. Forgetting to do this before first turning on the power could have unpleasant consequences. See also the section 'quiescent current adjustment'.

If the drivers (T6 and T9) are to be TO5-can types, one should take care to use the right p.c.-board holes. Note that Elektor boards also have the track layout printed on the component side, to serve as a guide in this kind of situation. Finally, do not overlook the cheapest component on the board... the jumper in series with R6.

Heat sink

The output devices T7 and T10 may be mounted, using TO3 mica insulators, on a common heat sink. The more efficient this heat sink is made, the greater will be the power that can be continuously delivered before things start to get hot. The thermal resistance (for each channel) should in any case be less than 2°C/W.

3d

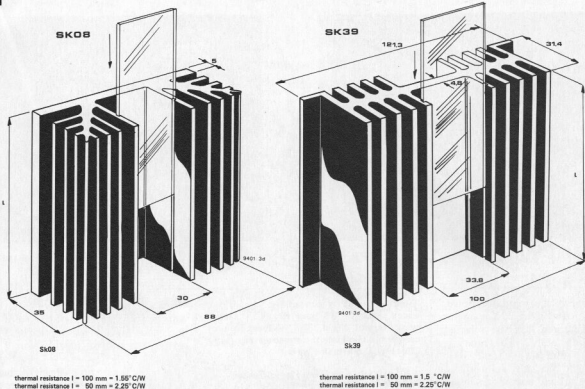

Figure 3. Various constructional details for the Equin.

3a: The assembly of L1/R28 (desirable with electrostatic loudspeakers).

3b: The cooling arrangements for T6 and T9; use the arrangement that matches the transistors in use.

3c: Mounting and connection of the power transistors T7 and T10 (bottom view), with and without use of a TO-3 socket.

3d: Typical extruded heat-sinks; the thermal resistance quoted applies to the blackened sink of length specified in the drawing.

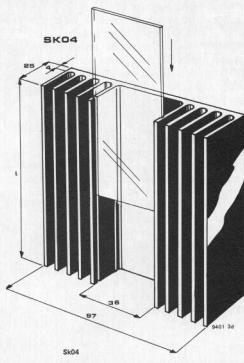

Figure 3d shows a few of the usual readily-available extruded aluminium heat sink types. The blackened type radiates better than the blank metal type, so that it is to be preferred for its lower thermal resistance (i.e. to ambient). The minimum height for a vertically mounted common heat sink is 75 mm, preferably 100 mm if the cabinet height will allow it. The transistors may alternatively be provided with individual heat sinks of 50...75 mm. When individual sinks are used, these are still connected to chassis by their fixing bolts, so that the transistors must still be properly insulated.

The optimum cooling effect is obtained when the sink(s) is (are) mounted with their fins vertical, since this takes advantage of the 'chimney effect'. Mounting the sinks inside the amplifier cabinet is generally not to be recommended, since the conditions of 'free radiation' and 'free convection' on which the sink design is based are then much more difficult to achieve. If this approach is unavoidable the cabinet should be provided with ample-sized grilles above and below the 'chimneys'. The cabinet must then also be mounted on feet.

Regarding the mounting of the power transistors themselves (see figure 3c) the following should be observed:

- smear heat-conductive silicon grease on both sides of the mica insulators; this will ensure an acceptable thermal contact;
- slip pieces (about 1 cm) of insulating sleeving over the base and emitter pins to prevent short-circuits;
- use trustworthy soldering tags for the collector leads.

It should go without saying that one should test the insulation between the mounted device and its heat sink, with an ohmmeter, before attempting to apply power.

Power supply

The Equin is designed to operate cor-

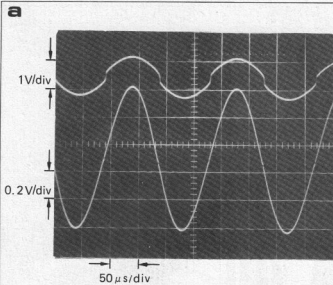

Photo A. Quiescent current too low. Upper trace: signal at T5 base (figure 1). Lower trace: output signal. The feedback cannot completely eliminate the crossover distortion. (Test signal: 5 kHz sine wave.)

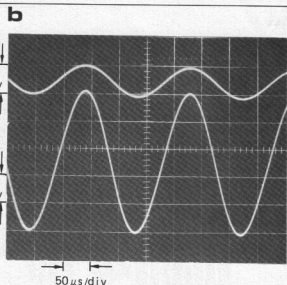

Photo B. Quiescent current set correctly.

3e: A possible final result: two power amplifiers plus supply in a 'tuck-away' case. Note that the wiring uses cable-clips and that the small heat-sink for the rectifier diodes must be mounted on insulators, since the screw-studs of these devices form the cathode contact (in this case).

rectly from a simple unregulated power supply circuit, see figure 2. The mains transformer required can be selected on the basis of table 2. The reservoir capacitors C12 and C13 should have sufficiently high working voltage and ripple-current ratings; components that meet these requirements will invariably also have adequate capacitance. A total of 3000...4000 μF will be in order.

The rectifier diodes must be rated to withstand the switch-on surge current (that often dims the room lights!), the periodic charging surges (the entire charge is delivered to the reservoir during the peaks of the AC waveform) and the average current (equal to the DC drain). The DC drain (minimum value for nominal output power!) is given in table 2.

The mains transformer may be a type with centre-tapped secondary, as shown, or one may use an untapped type in combination with a bridge rectifier.

The 'plus' feed to each amplifier should be provided with a 6.3 Ampere fast-blow fuse (Z2 and Z3 in figure 2). The fuse Z1 in series with the transformer primary should clearly be a slow-blow type. The use of panel-mounting fuse-holders is recommended.

Wiring

In a stereo amplifier each p.c. board must have its own supply lines. The same applies to the loudspeaker return lines, see figure 2. All these lines must be kept short and well away from the input wiring.

Note also that the chassis is connected to the supply-common junction point via the amplifier p.c. boards. Do not attempt to arrange this any other way. If the power amplifier and the preamplifier are in the same cabinet, the preamp will provide this connection. If the preamplifier is fitted in a separate housing the connection is made by linking the leads from point 2 on each power amplifier board at the chassis-mounted input connector.

The use of DIN-type loudspeaker con-

nectors is definitely not recommended. The miniaturised plug is very difficult to fit without risking a short circuit, whilst the combination of plug and socket often shows a rather high contact resistance. The best results are the easiest to obtain — use a solidly constructed banana plug and socket!

Preamplifier supply

Figure 6 shows how a preamplifier used with the Equin can be supplied with DC from the same rectifier circuit. The figure is drawn on the assumption that the Preco described elsewhere in this issue is to be used for the purpose.

The PNP transistor (any 5-watt type, fitted with a cooling fin) operates as a current-source. One advantage of this arrangement is that it starts up relatively slowly, reducing possible switch-on surges. When the power is turned on the voltage across the electrolytic (C_B in figure 6) builds up until the zenerdiode starts to conduct, providing a simple stabilisation. The LED in series with the zener is included as a convenient and reliable 'power on' indicator. Be sure to connect the LED in the forward

direction, otherwise the voltage on C_B will be too high. If the LED is not to be included, for any reason, then the zener voltage should be taken about 2 volts higher.

If a different preamplifier is to be used it may be necessary to change the zener voltage, the current source value, or both. The source current is given approximately by:

$$I = \frac{700}{R_a}$$

(in milliamps when R_a is in ohms).

It should be set at about double the expected preamplifier demand; a current in the LED of 10...30 mA is acceptable.

The 470 μF electrolytic (C_B) and the LED should be connected to supply common at the same point as the preamplifier output circuit (i.e. the linked points 2 of the power amplifier boards, or in the one-cabinet assembly alternative, at the preamplifier board).

Setting the quiescent current

It was made clear in part 1 how important the optimal setting of output stage quiescent (standing) current is for the 'crossover'. Three methods for achieving this setting will now be given.

Before any attempt is made to apply power to the circuit make sure that the slider of preset P1 is turned fully anticlockwise. If one forgets to do this there is a distinct possibility that the transistors in the output stage will get very hot very quickly!

The best way to find the optimum setting requires use of a sinewave generator and an oscilloscope. The amplifier is loaded by a resistor of 4...8 ohms (not critical) and driven with a 1 kHz sine to deliver about 1 watt into the load. The 'scope' is connected to view the waveform at the base of T5 (or T8). The quiescent current preset is now slowly advanced until the steep edges near the zero-crossing disappear from the trace. A check at higher frequencies and/or amplitudes may show a reappearance of these edges, in which

3e

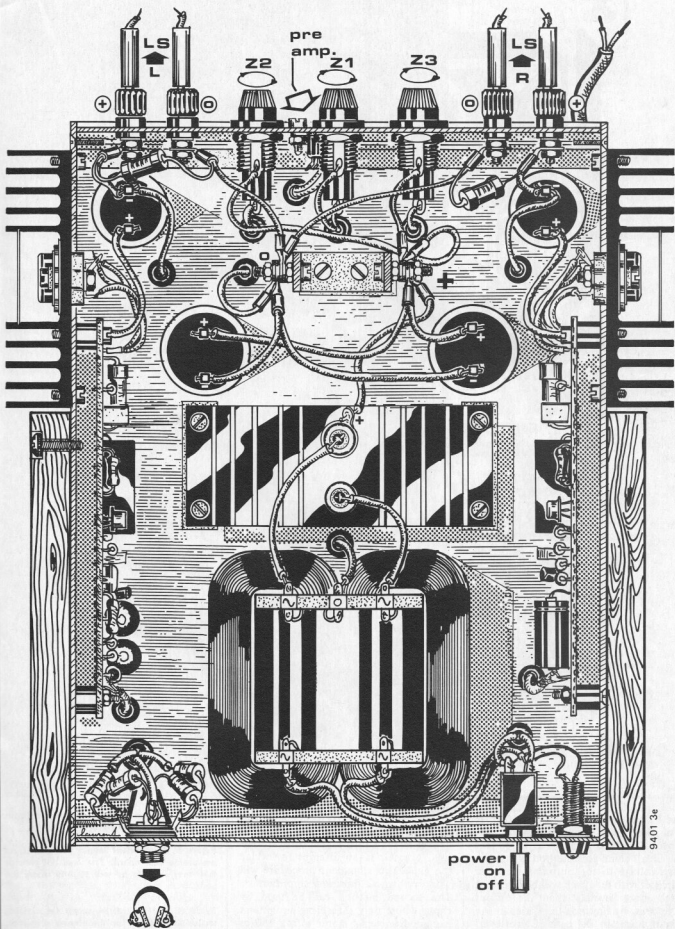

4

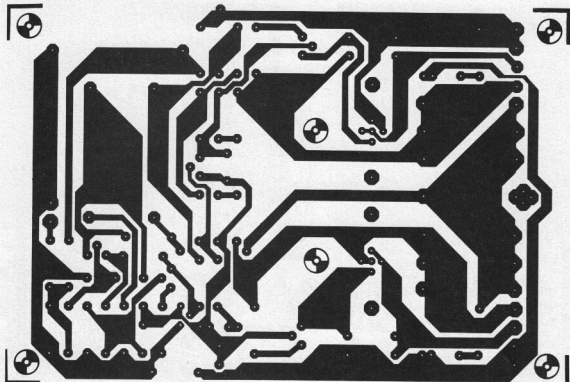

5

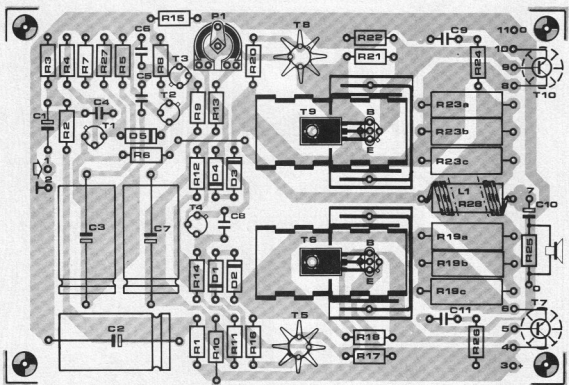

case P1 can be advanced a little further until they once again disappear. (See photos A and B).

The idea behind this method is that the drive voltage to the output stage in an amplifier with feedback will be distorted much more severely than the output waveform, by any non-linearities in the output stage. In the case of 'crossover' distortion, due to insufficient quiescent current, the output stage has a 'dead zone' centred on the zero-crossing. The

failure of the negative feedback in this zone will cause the earlier stages to deliver a very much higher drive voltage than normal, in an attempt to 'bridge the gap'. This alignment procedure will work well with almost any amplifier.

The second method can be used by those whose only measuring equipment is a good universal meter with a 250 or 300 millivolts DC range. The preset P1 is turned slowly clockwise until the voltage between points 6 (plus) and

Figure 4. The p.c. board layout for the Equin poweramp (one channel) (EPS 9401).

Figure 5. Component layout for the Equin poweramp p.c. board. The leads of resistor R10 may have to be sent slightly under the body.

Figure 6. A circuit arrangement for deriving an isolated supply for the control amplifier, from the main Equin rectifier circuit.

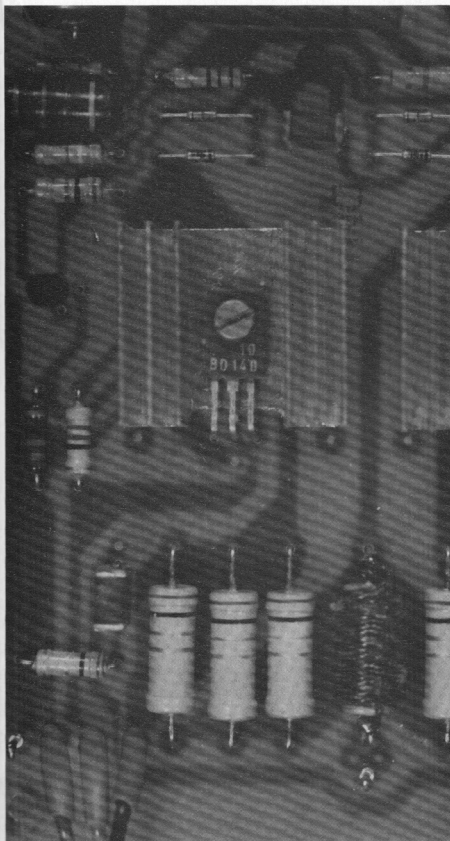

Parts list for figures 1 and 4.

Resistors:

R1 = 47 k
 R2 = 82 k
 R3 = 120 k
 R4, R17, R21 = 1 k
 R5 = 39 Ω
 R6 = 820 Ω
 R7 = 470 Ω
 R8, R24 = 10 Ω
 R9 = 4k7
 R10 = 470 Ω (1/2 watt)
 R11 = 3k9
 R12 = 3k3
 R13, R25* = 2k2
 R14 = 15 Ω (10 Ω with 60-volt supply)
 R15 = 2.2 Ω
 R16, R20 = 100 Ω
 R18, R22 = 68 Ω
 R19a, R19b, R19c,
 R23a, R23b, R23c,
 R28*) = 1 Ω (1 watt carbon or metal film)
 R26 = 1 Ω
 R27 = 1k5

Capacitors:

C1 = 2.2 μ /63 V
 C2 = 100 μ /63 V
 C3, C7 = 470 μ /40 V
 C4 = 1 n
 C5 = 10 p
 C6 = 33 p
 C8, C9, C11 = 100 n
 C10 = 2200 μ /50...63 V*)

*) see text

Semiconductors*)†)

T1 = BC557b, BC177b or equ.
 T2 = BC546b, 40361,
 (BC547b, BC107b or equ.)
 T3 = BC556a, 40362, (BC557a or b,
 BC177a,b or equ.)
 T4 = BC547b, BC107b
 T5 = BC546a, 40361, (BC547a or b,
 BC107a,b or equ.)
 T6 = BC556a, 40362, (BC557a or b,
 BC177a,b or equ.)
 T6 = BD140, 40410, 40595
 (BD138, BC161-16
 T9 = BD139, 40409, 40594,
 (BD137, BC141-16)
 T7, T10 = 2N3055, BD183, BDY20,
 BD130, BD182
 D1, D3*) = 1N4148 but substitute LED
 with 60 volt/4 Ω set-up
 D2, D4, D5 = 1N4148

*) see text for use of equivalent types

†) bracketed types only usable on 45 volt supply

Miscellaneous:

P1 = preset, 2k2 or 2k5
 L1*) = 2...4 μ H (wound on R28)

8 (minus) on the p.c. board reaches 35 mV. The quiescent current is then about 50 mA. This value is always rather higher than the optimum – but it is better to err on the safe side, when one cannot 'see' what one is doing, rather than to risk (audible) crossover distortion by setting the quiescent current too low.

A variant on the second procedure is to measure the total supply current of the undriven amplifier, setting this to 60 mA

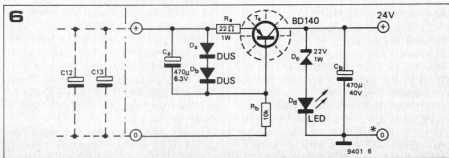
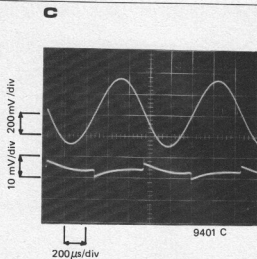

Photo C. This is what happens when the quiescent current is set too low! The upper trace (200 mV/div. vertical and 200 μ s/div. horizontal) shows the complete 1 kHz output signal. The lower trace (10 mV/div.) shows the distortion components, after suppression of the fundamental. It is just possible to see the 'crossover' irregularity in the upper trace. Comparison of the peak values of the two traces indicates about 1.6% distortion — distinctly audible! A normal 'distortion meter' will however read the RMS value of the spiky waveform, to give a much lower 'percentage'.

A plot of the spectrum of the distortion spikes, that occur at the zero-crossings, shows musically-disturbing harmonics up to the twentieth at levels barely lower than those of the third or fourth. When the quiescent current in the output stages has been correctly set for class B operation, the spikes disappear entirely. The distortion waveform is then mainly second harmonic. With the available instruments it was not possible to determine accurately how much of the distortion was already present in the input signal from the 'sinewave' generator — 0.05 . . . 0.1% at an estimate.



by means of P1. In this case the universal meter is set to read 100 mA f.s.d DC, then connected with correct polarity across the fuseholder for Z2 (or Z3). Turn the power on with fuses inserted, then remove a fuse to read the total current in the positive supply rail. Always start with P1 fully anticlockwise!

Class AB

Some people object on principle to class B operation, on the grounds that there will always be audible 'crossover'. These doubting Thomas's can carry out the following test. After ensuring that the output transistors have adequate heat sinks, turn P1 up until the standing current is 400 . . . 500 mA. (It may be necessary to reduce R13 somewhat in value.) The amplifier is now set to operate in class A, with an 8 ohm load, up to about 1 watt output; at higher drive levels it operates in AB. This displaces the crossover effects (which incidentally can be made exceedingly small by proper class B adjustment) to a higher level on the transfer curve, where they are thought by some to be potentially less troublesome. The test consists in setting one amplifier in class B and the other in class AB, paralleling the inputs, then arranging to switch the loudspeaker from one output to the other. (If ever there was an AB test, this is it . . .). The cleaner-sounding amplifier (if there is any audible difference) is the one to duplicate. Let somebody else label the switch — so that you don't know in advance which unit is B and which AB! That should settle the 'class war' . . .

The arbitrary selection of 1 watt as the power level for coming out of class A operation is based on the behaviour of typical music signals. Their crest factor is invariably such that an amplifier being fully driven in the signal peaks (and *that* is loud) will be delivering an average power of around one, maybe two watts. (See the article 'What's watt?', Elektor 12, p. 455.)

Headphone feed

Due to the great variation in impedance and sensitivity between the available types of headphones, it is only possible to give indications here as to how the feed should be taken from the power output.

As a general rule, one may connect high-impedance units (e.g. Sennheiser HD 414 or HD 424) directly to the loudspeaker sockets. Low-impedance 'cans' are best connected via a resistive voltage divider (see figure 1) to the power output. The alternative arrangement, using a series resistor only, is not recommended; the very high driving impedance will tend to adversely affect the bass reproduction. With 8-ohm headphones a value of 22 . . . 39 ohm ($\frac{1}{2}$ watt) will be suitable for R25b. The series resistor R25a is then chosen so high that the noise voltage at the amplifier output is sufficiently attenuated — but not so high that the gain control has to be turned up further than is normal for use with loudspeakers. R25a can be taken at 100 . . . 150 ohm (1 watt) as a starting point for experiment.

If the voltage divider is to be wired permanently into the circuit the bleeder-resistor R25 may be omitted.

Final remarks

The input impedance of the Equin is fairly high (about 40 k Ω). It is nonetheless recommended that the pre-amplifier used should have an output impedance lower than 5 k Ω . The reason is that the source impedance 'seen' by the power amplifier is effectively in series with resistor R4. Together with C4, this resistor forms a low-pass network that sets the 'open loop' rolloff frequency of the amplifier (see part 1). The output impedance of the Preco depends somewhat on the position of the left-right 'balance' control — but is always below 1 k Ω .

This low impedance has the advantage that a long run of screened cable is permissible between the power amplifier

and the (remote) control amplifier.

The resistor-damped series inductor (L1, R28) at the amplifier output is included to improve the 'impulse-response' (i.e. the performance with 'spiky' music signals or squarewaves) when the load is essentially capacitive, as for example when the amplifier is used with an electrostatic loudspeaker.

If this precaution is not required, a jumper wire may be connected instead of L1/R28 on the p.c. board.

One way of obtaining the required value for L1 is to wind 40 turns of 0.6 diam eter enamelled copper wire (23 S.W.G.), in two layers, over R28 (see figure 3). A few drops of plastic glue will be helpful here. Be sure that the coil ends are carefully cleaned of enamel.

If thicker wire is to be used (because it happens to be on hand), a greater number of layers will be required. For example, wire of ϕ 1 mm (19 S.W.G.) will require 36 turns in three layers. This can be done using a round pencil (about 7 mm diameter) as a former. When the coil is complete it can be slipped off the pencil and over the resistor. The carefully cleaned ends can then be soldered onto the suitably-bent end-leads of R28.



Supply Decoupling

A circuit is only as good as its power supply. Even the best designed circuits can be upset by supply ripple, poor regulation, mains transients and power supply instability. IC voltage regulators have taken much of the donkey work out of power supply design for many applications, but the problems do not always end there.

Power supply circuits are usually designed almost as an afterthought. The circuit requiring power has probably been developed on the bench using the ubiquitous lab power supply. In general, a power supply for an electronic circuit should approximate an ideal voltage generator as well as possible. This means that the output voltage should remain constant over the normal output current operating range; in other words, the supply should have zero output impedance.

The supply voltage should not only remain constant under static conditions, but should also still remain constant when dynamic changes of current are occurring. As mentioned in the introduction, IC voltage regulators make it easy to achieve these objectives *at the output terminals of the supply*, but at points in the circuit remote from the supply the situation may be very different.

Depending on the type of circuit, the inductance of supply wiring and p.c. board tracks, though small, may have a dramatic effect. The worst offenders in this respect are probably TTL logic circuits. When the output state of a TTL gate changes this results in a change in the current drawn by the circuit of around 2 mA. A static current difference of 2 mA would probably result in a supply voltage variation of a few microvolts. The dynamic situation can be very different,

however.

The fall (or rise) time of a TTL gate from logic 1 to logic 0 level is of the order of 10 nanoseconds. The rate of change of current $\frac{di}{dt}$ is therefore 2 mA in 10ns or 200,000 amps/sec. The voltage V across an inductor L equals $L \frac{di}{dt}$, so a wiring inductance of the order of 1 μ H between the supply and the point where the current change occurred would result in a voltage drop of 200 mV.

This is, of course, a gross oversimplification, but it does demonstrate the sort of voltage transients that can occur on supply lines in TTL circuits. When such transients are of sufficient magnitude they can cause gates to change state and can cause spurious triggering of flip-flops, counters and monostables.

The problem can be attacked in several ways. The simplest approach is to provide local decoupling of the supply at various points in the circuit by means of small capacitors, typically 10 to 100n. These should preferably be ceramic types which have low self-inductance (figure 1a). Nine times out of ten this will effect a cure, but in some cases the cure can be worse than the disease, for it is possible that the capacitor will form a resonant circuit with the inductance of the supply lines. When this is excited by the switching transients of the TTL the problem can be magnified rather

than reduced.

The solution here is to damp the resonant circuit by including a resistor in series with each capacitor. 1 Ω carbon composition resistors should be used for this purpose (film types often have a high self-inductance). This is shown in figure 1b. An alternative to this is to use electrolytic capacitors of say 10 $\mu\text{F}/6.3\text{ V}$. Modern electrolytics have fairly low self-inductance, but the internal resistance is often sufficiently high to provide adequate damping.

Figure 2a shows the use of RC combinations to decouple several IC's fed from the same supply rail. Rather than using a single supply rail running from one IC to another a better solution, whenever possible, is to run separate supply rails from the power supply to each IC or group of two or three IC's. In this way interaction between the various IC's is reduced, since the self-inductance of each supply line actually helps to isolate the IC's from one another (figure 2b).

Another useful tactic is to make the supply lines fairly thin, as this increases their resistance and thus reduces the Q of the self-inductance. While on the subject of separate supply lines it is worth considering 'on-card stabilising'. In complex TTL systems, where there are several p.c. boards, a separate IC voltage regulator is often used on each board. This has several advantages:

1. Interaction between boards is virtually eliminated.
2. Heat dissipation is spread over several IC regulators rather than being concentrated in one central power supply, so cooling problems are reduced.
3. Each board can be fed from a remotely located unregulated supply without worrying about voltage drops along the supply lines (provided the voltage reaching the boards is sufficient for the regulators to operate).

Diode decoupling

Of course, not every circuit will be used with a stabilised supply, there are cases where it is simply not necessary or is uneconomic. In such cases the simple transformer, bridge rectifier and smoothing capacitor is generally used (figure 3). Off load this gives a reasonably constant d.c. voltage, but as the load current increases the supply will exhibit an increasing ripple voltage (see figure 5).

Some times a circuit requiring a ripple-free supply at a relatively low current, must be operated from the same unregulated supply as a circuit requiring a higher current. A typical example of this is an audio amplifier where the preamp is fed from the same supply as the power amplifier. Generally, the power amplifier can tolerate higher ripple voltages than the preamp. Clearly some way must be found of isolating the preamp from the ripple voltage caused by the power amplifier.

This can be achieved by RC filtering, as in figure 3. The high current supply is

Figure 1a. The connecting wires between the stabilised supply (on the right) have a certain self-inductance. Rapid changes in load current can cause voltage drops across these inductances. A decoupling capacitor may help suppress this.

b. Under certain conditions the decoupling capacitor and lead inductances may form a resonant circuit, aggravating the problem. This can be damped by a low-value carbon composition resistor in series with the capacitor.

Figure 2a. In a large circuit or system, decoupling should be employed every one or two IC packages. However, stringing the supply along from one IC to the next is not the best way to eliminate coupling along the supply lines.

b. Here each IC or small group of IC's has its own supply lines. The self-inductance of the supply lines now actually inhibits coupling back from one IC to another.

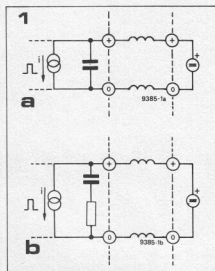

taken from point 1, and a filtered, low current supply is taken from point 2. Clearly, the larger the values of R1 and C2, the more ripple-free will be the supply. However, R1 cannot be too large, otherwise increases in the load current I_2 may cause the voltage at point 2 to drop below an acceptable value. On the other hand R1 cannot be too small as increases in the load current I_1 may cause current to be 'robbed' from C2, should the voltage on C1 fall below that on C2.

These problems may be solved by using the circuit of figure 4. C2 will charge up to a voltage equal to the peak voltage on C1 minus the diode voltage drop. C2 will discharge at a rate determined by the time constant $C2/R_L$, regardless of what happens to the voltage on C1. Even if C1 were discharged by a momentary short circuit the voltage on C2 would be unaffected. The ripple level on C2 remains constant (for constant I_2), whatever the ripple on C1, as shown in figure 6.

RF Decoupling

It is essential in RF circuits that none of the RF signal appears on the supply lines. Not only does the possibility of unwanted radiation from the supply lines exist, there is also the chance of RF bring coupled back into other parts of the circuit. This can lead to instability in the case of positive feedback, or loss of gain in the case of negative feedback. Wherever possible, RF circuits should be split up into units handling a single frequency or band of frequencies. Thus, for example, a double conversion receiver might be split up into front-end,

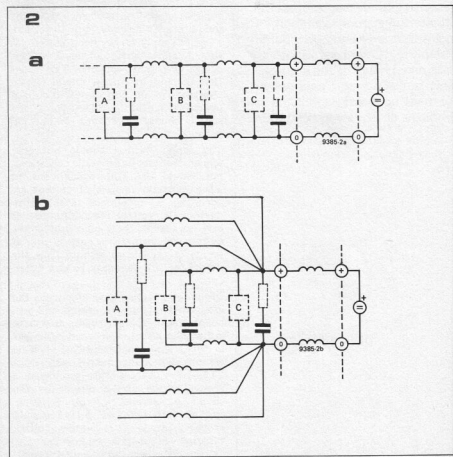

3

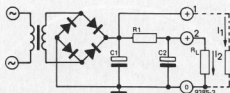

Figure 3. Where a ripple free supply is taken from a non-ripple free supply it may be smoothed by an RC filter.

4

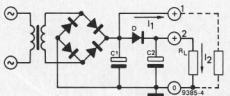

Figure 4. Substitution of a diode for R1 gives a great improvement. Once C2 has charged it is completely isolated from C1 and the ripple depends solely on the current drawn by RL.

5

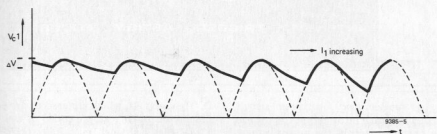

Figure 5. Ripple voltage on C1 for increasing load current I_1 .

6

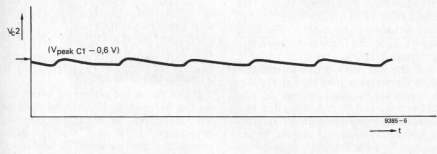
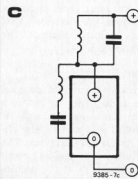
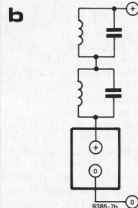
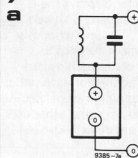

Figure 6. The ripple voltage on C2 remains constant (for constant I_2) whatever the ripple voltage on C1.

Figure 7. Three methods of supply decoupling in RF circuits. a. Narrowband filter. b. Wide stopband filter. c. Combination of parallel and series resonant circuits for VHF use.

7



first i.f. amplifier, mixer, BFO, second i.f. amplifier, demodulator and a.f. stages. Each of the stages would have its supply connection via a parallel resonant circuit tuned to the centre frequency handled by that stage (e.g. 10.7 MHz in the case of an f.m. i.f. amplifier). This will act as a wavetrap to prevent RF getting back onto the supply lines (figure 7a).

Where the circuit handles a wide range of frequencies it may be necessary to use a filter with a wider stopband by connecting two or more resonant circuits (of different frequencies) in series, as in figure 7b.

At very high frequencies the use of a series resonant circuit to shunt unwanted

RF signals down to ground is also recommended. The combination of parallel resonant and series resonant circuits is shown in figure 7c. For circuits working in the hundreds of megahertz the required inductance for the series circuit can be obtained simply by trimming the capacitor leads to an appropriate length. **M**

digisplay

This logic tester displays the states of sixteen binary signals (either '0' or '1') simultaneously, in the convenient form of a 4 x 4 matrix on an oscilloscope screen. The facility for automatic Karnaugh mapping is of particular interest, although some other uses of the tester are described.

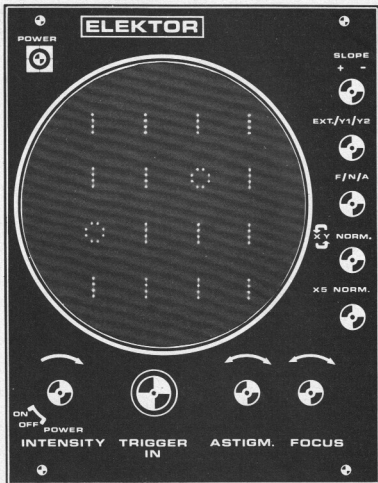

The ways of testing binary logic signals are many and various with the involved test equipment being more or less complicated. This article describes a circuit, dubbed the 'Digisplay', which tests the states of sixteen binary signals and displays the results on an oscilloscope screen in the particularly convenient form of a four-by-four matrix of '0' and '1' characters. The Digisplay, which uses conventional TTL throughout, may be used in a variety of ways, viz:

- (1) to test integrated circuits;
- (2) to display logic states in the form Karnaugh maps;
- (3) as a programmed 16-bit pulse generator.

An internal clock pulse generator of fixed frequency is used in the circuit, but a facility is provided for connecting an external clock should a variable frequency be required.

The circuits which generate the characters '0' and '1' and place them in matrix form on the screen are described first and then the various uses of the Digisplay are explained.

Block Diagram

The Digisplay is shown in block diagram form in figure 1. In order to obtain a display on the screen of '0' and '1' characters arranged in a matrix, the circuit performs two main functions. The first is to produce horizontal and vertical scanning information at the oscilloscope terminals to enable a '0' or a '1' to be written on the screen; the second

is to superimpose on these signals further scanning information to position the character within the matrix square required. The '0' character is written as a circle of eight dots and the '1' is derived from the '0' by suppressing the horizontal scanning signal.

The character generating signals are derived from clock pulses which are fed into a divide-by-eight counter. The three outputs, L, M and N are re-encoded into the signals E, F, G and H of which E and F are fed to a digital-to-analogue (D/A) converter whose output supplies the vertical scanning signal to the oscilloscope, and G and H are fed to a second D/A converter which supplies the horizontal scanning signals. It can therefore be seen that each state of the divide-by-eight counter corresponds to one of the eight dots in the character. (The details of the signal coding are given later.)

The matrix generating signals are derived from a divide-by-sixteen counter which is driven by the N output from the divide-by-eight counter. Thus each state of this divide-by-sixteen counter corresponds to one of the squares in the matrix. The four outputs from the counter, W, X, Y and Z, are also fed to the two D/A converters as shown, where they are superimposed on the voltages obtained from E, F and G, H such that each character is positioned in its correct square in the matrix.

The outputs W, X, Y and Z are also used to produce the test signals A, B, C and

D. These signals, which are used to drive the circuit under test, are coded in such a way that Karnaugh maps may be realised on the display, (see 'Karnaugh Mapping'). For each state of the drive signals ABCD the multiplexor produces the result \bar{S} (the inverse of the selected input signal S) which is used to inhibit the horizontal scanning signal whenever a '1' needs to be displayed. Each part of the Digisplay circuit is now described in detail.

Tracing the Characters

Figure 2 shows the path along which the tracing beam steps in order to produce the characters. In each dot position (numbered 0-7) the tracing beam pauses for the duration of one clock pulse. The figure also shows how the '1' is derived from the '0' with the horizontal movement inhibited. (It is true that this will cause the '1' to be slightly brighter than the '0', but in practice this is barely perceptible and can be ignored.) The apparent misalignment of the two characters within a square is corrected as described later. Each character is traced out more than a hundred times each second, so that a '0' appears as a circular arrangement of eight dots and a '1' as a vertical line of four dots. The horizontal and vertical co-ordinates of the eight positions, which correspond to the scanning information which must be supplied by the two D/A converters, are given in the tables of figure 2.

The circuit which controls the movement

1

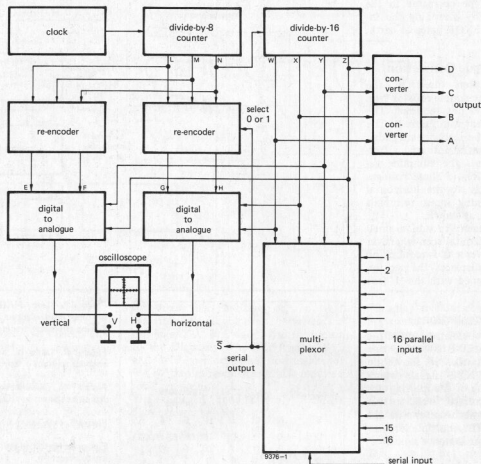

of the tracing beam is shown in figure 3 and operates as follows: a simple multi-vibrator comprising two NAND gates, generating a signal of approximately 20 kHz, feeds clock pulses into a divide-by-eight counter consisting of three flip-flops in an IC7493 (the fourth flip-flop is left unused). The counter outputs L, M and N are used as inputs to a re-encoding circuit as previously described. The re-encoding which takes place is shown in the table of figure 4 and corresponds to the following equations:

$$E = \overline{L}$$

$$F = \overline{LMN} + \overline{LMN} + \overline{LMN} + \overline{LMN}$$

$$G = \overline{M} \cdot \overline{S} = M + S$$

$$H = \overline{N} \cdot \overline{S} = N + S$$

where \overline{S} is the multiplexer output. The re-encoding circuit shown in figure 5 consists of ICs 7400, 7410 and 7420. The two remaining NAND gates in the IC 7400 are used in the clock pulse generator (see figure 3). The \overline{S} signal inhibits G and H in order to trace a '1', i.e. when \overline{S} is '0'.

Plotting the Matrix

The path the tracing beam takes through the matrix while drawing sixteen characters is shown in figure 6. The path is achieved by adding horizontal and vertical staircase voltages to the character scanning signals. Figure 7 shows the circuit, which consists of a divide-by-sixteen counter IC 7493 whose outputs W and X are input to two gates in an IC 7486 and outputs

Figure 1. Block Diagram. Clock pulses are re-encoded to drive logic circuit under test and to produce characters '0' and '1' on the screen. Circuit results are decoded to select either '0' or '1'.

Figure 2. Path followed on oscilloscope screen by character tracing beam. Tables show horizontal and vertical scanning coordinates.

Y and Z are input to two gates in an IC 7404. The outputs from these gates are used respectively to produce the horizontal scan after each character and the vertical scan after each row of four characters.

Some types of oscilloscope show a deflection to the left for a positive voltage at the horizontal input terminal,

2

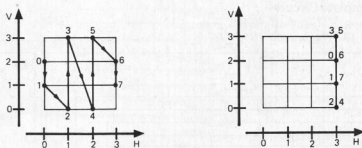

9376-2

CHARACTER 0			CHARACTER 1		
DOT NUMBER	HOR. CO-ORD.	VERT. CO-ORD.	DOT NUMBER	HOR. CO-ORD.	VERT. CO-ORD.
0	0	2	0	3	2
1	0	1	1	3	1
2	1	0	2	3	0
3	1	3	3	3	3
4	2	0	4	3	0
5	2	3	5	3	3
6	3	2	6	3	2
7	3	1	7	3	1

which would present a mirror-image matrix. This may be corrected in the Digisplay simply by strapping the input I of the two EXOR gates to earth, as shown.

Digital-to-Analogue Conversion

The D/A converters used in the Digisplay are of the simple resistor type as high accuracy is not required. The two circuits are shown in figure 8. The currents through the resistors are added algebraically so that a potential difference appears across the summing resistors R_{hor} and R_{vert} . These voltages are applied directly to the horizontal and vertical scanning input terminals of the oscilloscope, as shown.

Resistor R_S is present to add a small voltage to the horizontal scan whenever \bar{S} is '1' i.e. whenever a '0' is required on the screen. This displaces the written '0' so that it is aligned with the '1' (see figure 9).

Input/Output Correlation

The circuit which correlates each of the Digisplay inputs (E0-E15) with one square of the matrix, is shown in figure 10. The WXYZ signals which control the plotting of the matrix, also drive the multiplexor IC 74150 so that the \bar{S} signal is in synchronism with the matrix position. The multiplexor also has an over-riding serial strobe input.

Karnaugh Mapping

The signals ABCD which are used to drive the circuit under test are coded to enable Karnaugh maps to be displayed. The layout of a Karnaugh map for inputs A, B, C and D is given in figure 11. It can be seen that two adjacent matrix squares (vertically as well as horizontally) never differ by more than one element. The conversion used in the Digisplay is given in the table of figure 12, where the circuit which performs the conversion is also shown.

The Complete Circuit

The complete circuit diagram is given in figure 13. The internal (N1, N2), or

3

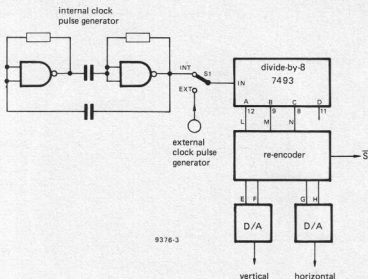

Figure 3. Two NAND gates in tandem, forming multivibrator clock pulse generator driving character tracing circuits.

Figure 4. Table of binary signals from re-encoder to trace either '0' or '1'.

Figure 5. Re-encoder circuit producing signals as shown in table of figure 4.

Figure 6. Path taken by beam to plot matrix.

Figure 7. Matrix-plotting circuit, also showing image inversion.

Figure 8. Digital-to-analogue converters consisting of resistor networks.

Figure 9. Character alignment.

Figure 10. Multiplexor IC 74150 circuit diagram and pin connections.

4

character	IC7493	re-encoder output					
S	N	M	L	H	G	F	E
0	0	0	0	0	0	1	0
0	0	0	1	0	0	0	1
0	0	1	0	0	1	0	0
0	0	1	1	0	1	1	1
0	1	0	0	1	0	0	0
0	1	0	1	1	0	1	1
0	1	1	0	1	1	1	0
0	1	1	1	1	1	0	1
1	0	0	0	1	1	1	0
1	0	0	1	1	1	0	1
1	0	1	0	1	1	0	0
1	0	1	1	1	1	1	1
1	1	0	0	1	1	0	0
1	1	0	1	1	1	1	1
1	1	1	0	1	1	1	0
1	1	1	1	1	1	0	1

5

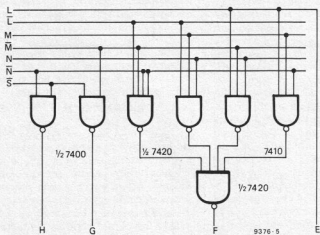

6

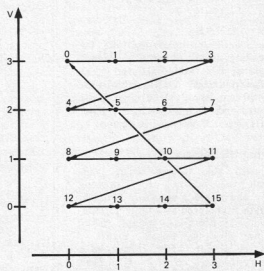

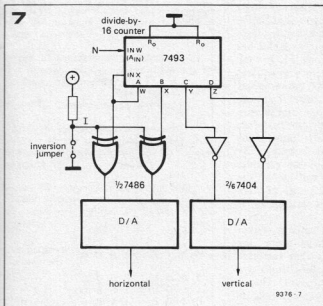

the external, clock pulse generator drives the counters via the INT/EXT switch and the diode clippers. The divide-by-eight counter consisting of three of the four flip-flops of IC6 supplies the pulses L, M and N which are re-encoded as previously described by N3-N9 and N14-N16 to drive the two D/A converters supplying the horizontal and vertical character tracing voltages.

Signal \bar{S} is input to N3 and N4 to determine whether a '0' is drawn or the '1' derived from it. It also supplies the small additional voltage required to align the '0' with a '1'.

The divide-by-sixteen counter IC7 is driven by the N pulse from IC6, and it supplies pulses W and X for the horizontal matrix plotting and pulses Y and Z for the vertical, via N10, N11 and N17, N18 respectively. N10 and N11 are also used to correct image inversion where necessary.

After D/A conversion as described the matrix plotting staircase voltages are added to the character generating voltages with the resulting voltages appearing across R_{hor} and R_{vert} .

The signals W, X, Y and Z are also used

to drive the multiplexor, so that synchronism is achieved between the test signals A, B, C and D and the inputs to the Digisplay. The EXOR gates N12 and N13 perform the conversion of WXYZ into the sequence ABCD required for Karnaugh mapping. The Digisplay requires only a single 5 volt power supply.

Applications

The Digisplay may be used to test ICs by making the following simple connections: connect the IC ground to the

Digisplay ground; connect the Digisplay horizontal and vertical outputs to the corresponding terminals of the oscilloscope; connect the sixteen multiplexor inputs of the Digisplay to the corresponding IC pins (for which 'testclips' would be convenient). The internal clock of the Digisplay is used. No special precautions are necessary, although it must be remembered that these connections will augment fan-outs by one, but this should not present problems in most cases.

The matrix on the screen will now dis-

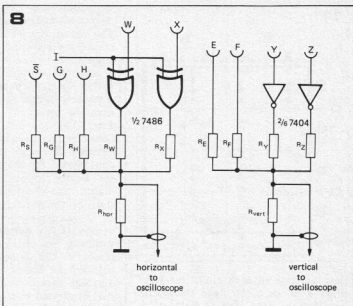

10

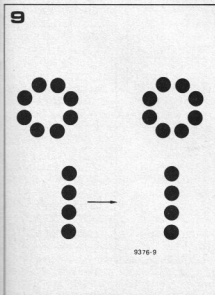
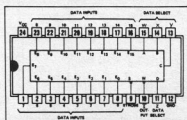
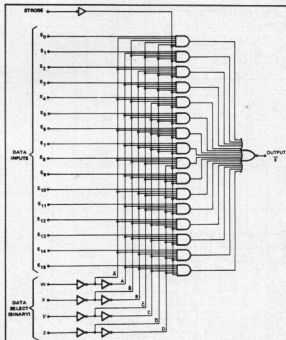

11

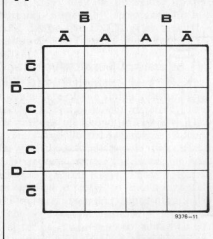

9376-11

play the state of each pin of the IC as either a '0' or a '1'. Read the matrix from left to right, top to bottom for pins 1 to 16 respectively. Open-circuit inputs and broken connections will show as logic '1's, as is usual for TTL circuitry.

Figure 14 shows an example of an IC 7442 binary-coded-decimal to decimal decoder with binary five (0101) applied to its inputs, and the resulting display.

The Digisplay may be used for automatic Karnaugh mapping because of the way test signals ABCD are coded. Karnaugh maps are particular forms of truth tables, arranged in a standard way

to permit easy verification of logic operations and rapid diagnosis of faults. The layout of a Karnaugh map for logic operations involving four variables has already been given in figure 11. In such a map the variables refer to squares within the matrix such that two adjacent rows or columns never differ by more than the inversion of one of the variables. The top and bottom rows are considered to be adjacent, likewise the extreme left and right columns. By convention, the states of the variables are written round the outside of the matrix, and the logical result of each state of the variables is written as '1' or '0' (as appropriate) in the relevant square. If two adjacent squares (either vertically or horizontally) show the result '1' this indicates that the variable and its inverse labelling those two adjacent squares is redundant. This is best illustrated with an example. Figure 15 gives a Karnaugh map for the 'g' output of an IC 7447 binary-coded-decimal to 7-segment decoder, with inputs ABCD from the Digisplay. With reference to the circuit diagram, the 'g' output is derived in the following manner: two AND gates have their outputs inverted and ANDed to give

$$\overline{ABC} \cdot \overline{BCD} \quad \dots \dots \dots (1)$$

at the input of the final gate. Using De Morgan's theorem the above may be rewritten

$$\overline{ABC + BCD} \quad \dots \dots \dots (2)$$

12

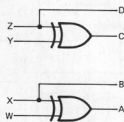

9376-12

W	X	Y	Z	A	B	C	D	position in the matrix
0	0	0	0	0	0	0	0	1
1	0	0	0	1	0	0	0	2
0	1	0	0	1	1	0	0	3
1	1	0	0	0	1	0	0	4
0	0	1	0	0	0	1	0	5
1	0	1	0	1	0	1	0	6
0	1	1	0	1	1	1	0	7
1	1	1	0	0	1	1	0	8
0	0	0	1	0	0	1	1	9
1	0	0	1	1	0	1	1	10
0	1	0	1	1	1	1	1	11
1	1	0	1	0	1	1	1	12
0	0	1	1	0	0	1	1	13
1	0	1	1	0	0	1	1	14
0	1	1	1	1	1	0	1	15
1	1	1	1	0	1	0	1	16

13

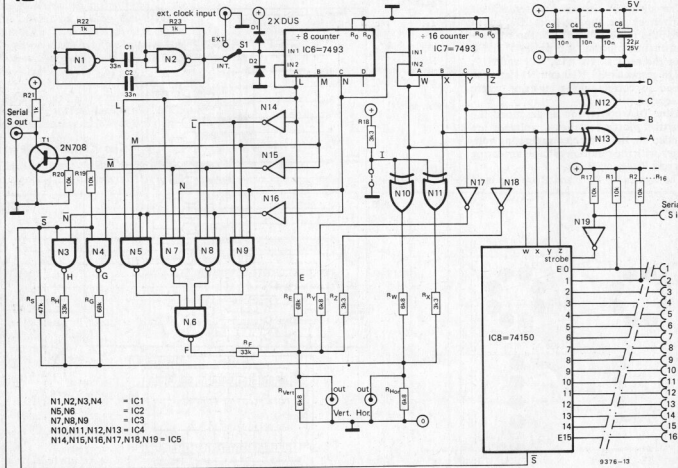

9376-13

Figure 11. Layout of a four-variable Karnaugh map, which could be used as transparency overlay on screen.

Figure 12. Binary pulse sequence W, X, Y, Z is converted to A, B, C, D required for Karnaugh mapping.

Figure 13. Complete circuit diagram.

Figure 14. Example display obtained of four inputs and ten outputs of IC 7442 BCD-decimal decoder with binary 5(0101) applied at input.

Figure 15. Karnaugh map for 'g' output of IC7447 BCD to 7-segment decoder obtained on oscilloscope screen by means of the Digisplay.

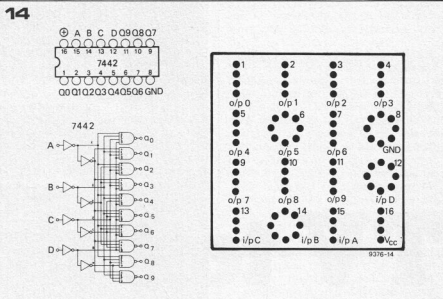

The inversion by the final gate gives the output 'g' of

$$ABC + \bar{B}\bar{C}D \dots \dots (3)$$

Now consider the Karnaugh map. The top row has two adjacent '1's which pinpoint the variable A as redundant for this term, i.e.

$$\bar{C}DAB + \bar{C}DA\bar{B} = \bar{C}DB \dots \dots (4)$$

The other two adjacent '1's pinpoint D as redundant, i.e.

$$ABC\bar{D} + ABCD = ABC \dots \dots (5)$$

Comparison between (3), (4) and (5) indicates that the map gives a true picture of the output 'g'.

Another use of the Digisplay is as a programmed pulse generator. This is achieved by means of the multiplexor. If, at this point, a variable frequency is required, an external clock pulse generator can be connected. Every bit within one full pass of the multiplexor can be defined as a unique combination of the variables W, X, Y and Z. The complete set of the functions is shown in figure 12, and each function may be correlated with one of the multiplexor inputs E0-E15. For this application the \bar{S} output of the multiplexor has been inverted by T1 so that the true state of the input is available at S. By connecting relevant multiplexor inputs either to ground or V_{CC} , the desired combination of sixteen pulses will be available at S. This may be verified by connecting the Digisplay to an oscilloscope in the usual way.

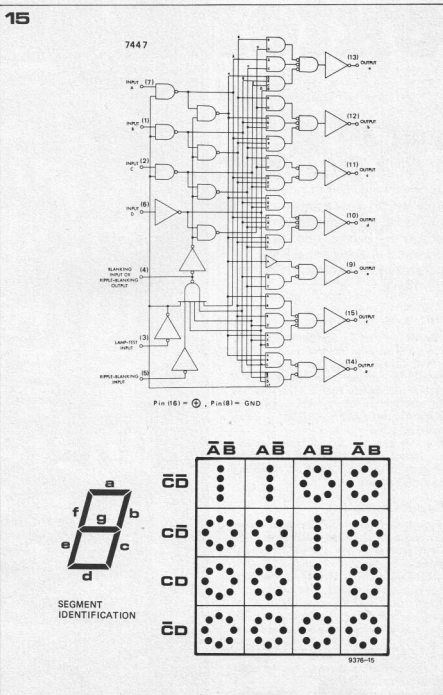

TV tennis extensions

part 3

This article gives circuits for producing synchronous sound effects that can be added to the original TV tennis game. Some variants of the basic game are also described.

The fun of playing the game cannot be complete without the excitement of the sound of the smash and bounce. The additional circuits here will produce a variety of sounds that not only create an atmosphere of 'presence' but also gives unmistakable indication when a mark is scored.

For this purpose, five different sounds are provided; the pitch and decay time of each of them can be varied according to personal taste.

Circuit Description

The circuit diagram of figure 11 shows the smash and bounce sound generators. Four generators use COS-MOS NAND gates. The fifth (T17 and T18) is a multivibrator; it is unique in that it is not connected to the power supply! When flip-flop FF3 (see figure 8 of part 1) indicates a mark scored by applying a positive step to the circuit of figure 11, it sets off a short and gradually decaying oscillation. The duration of the oscillation depends on the value chosen for C66.

The active elements of the other signal

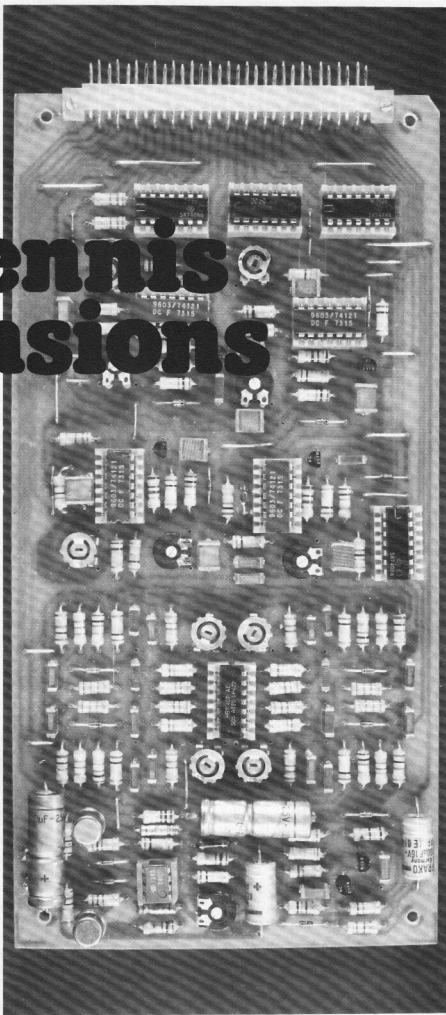

12

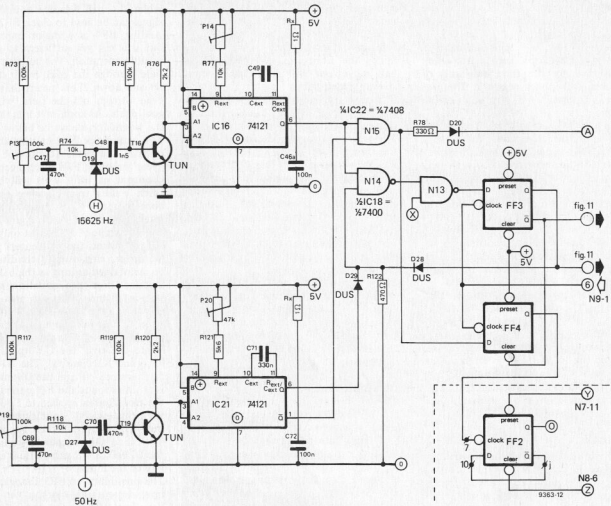

only work properly if contact X makes before (or simultaneously with) contacts Y and Z. If this is not the case an unwanted 'goal' sound will be heard when serving; points Y or Z must then be used instead of point X.

Hole-in-the-net

As far as we know, this is an entirely new game. A more simple version does exist, where one player has to send the ball through a 'hole in the wall'. The 'hole in the net' game is rather more complicated. The field and the horizontal position of the players are the same as in the tennis game. However, it is impossible to play normal tennis because the ball bounces back off the 'net'.

There are three ways to get the ball into the opponent's side of the field. The first two are holes in the net, one corresponding to each bat. As each player moves his or her bat up and down, the corresponding hole in the net moves up and down with it. The trick is to hit the ball and then quickly place the hole in the path of the ball.

The third possibility to get the ball across is sheer luck... If the ball hits the net at precisely the right moment, the flip-flop that determines the direction of the horizontal ball movement may receive two clock pulses. The ball will then change direction twice, with the 'net' result that it flies straight over the centre line.

Obviously this game is more difficult

than an ordinary tennis game, since one must not only hit the ball but also position the hole in the net correctly. A novice at the game will quite often send the ball into his own goal.

Adding this extension to the original game requires only very few modifications (see figure 13).

Three gates are added to the centre line ('net') generator. These gates use the vertical 'bat' signal to blank the video signal for the centre line. As a result, the vertical position and the size of the holes correspond exactly to those of the bats.

An additional flip-flop is required to bounce the ball back off the net. The circuit is similar to that used in the football game for rebounding from the

13

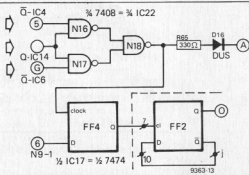

14

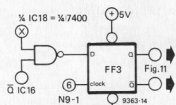

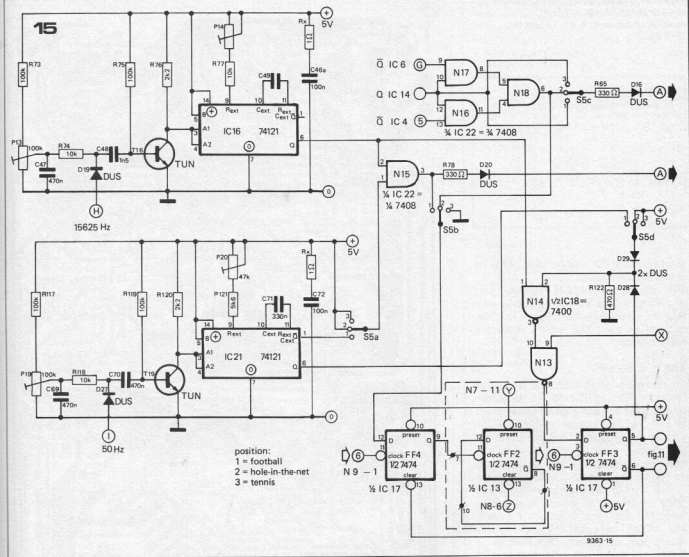

vertical boundaries. FF4 can be used for both circuits, provided one or two switches are added.

There is no gap in the vertical boundaries ('goal') for this game, so a mark is scored when the ball crosses a vertical boundary at any point - as in the tennis game. The same sound effects circuit can therefore be used for both games (figure 14).

Combining the three games

The diagram of figure 15 shows that it is relatively simple to design a combined circuit suitable for all three games: TV tennis, football and hole-in-the-net. For clarity's sake only those sections of the circuit are shown where modifications are to be carried out. The letters at the various connection points refer to the interface with the original TV tennis circuit described in part 1.

In the new circuits, 1Ω resistors (Rx) are included in series with the decoupling capacitors for the integrated circuits. It is recommended to add these resistors to the basic circuit as well; they will improve picture quality.

The amplifier

The amplifier design shown in figure 16 is quite straightforward but adequate for the purpose. The signals from the sound effects generators (figure 11) are

Figure 12. Additional circuit for 'football'. Part of the vertical boundary is blanked to simulate the goal.

Figure 13. Holes in the net are simulated by partial blanking of the centre line. This only requires a minor addition to the circuit for the centre line.

Figure 14. Circuit addition to control a sound effect generator.

Figure 15. Combination of the additional circuits for hole-in-the-net and football requires a selector switch.

Figure 16. The audio amplifier is quite straightforward.

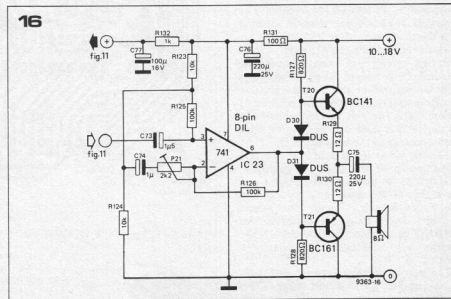

Figure 17. The p.c. board and component layout for all additional circuitry, i.e. the combination of figures 4, 6, 11, 15 and 16. (EPS 9363).

Missing Link

In the component layout (figure 17), the capacitor between IC16 and R77 is C49, not C44. In the parts list, C49 should be 1 n.

P11 = 100 k
P12 = 22 k
P13 = 100 k
P14 = 47 k
P19 = 100 k
P20 = 47 k
P21 = 2k2

amplified to the comfortable level of about 750 milliwatts.

The volume control (P21) can be a preset. When setting this control, take care that the amplifier is not overloaded; this is quite audible, the sounds develop a nasty twang.

The p.c. board

Combination of the circuits shown in figures 4, 6, 11, 15 and 16 gives the total circuit for the TV tennis described in this and the preceding article. The printed circuit board for these additions is the same size as the p.c. board for the basic game, so that it can be mounted on top of the latter. All connections are at one end of the board, so that it can easily be hinged up should final adjustments to the basic board be required. The wiring between the two boards should not be neatly bundled; it is better to run the wires criss-cross to reduce crosstalk.

Final adjustments

Few problems are likely to arise if the basic equipment has been correctly set up.

With S5 switched to 'TV tennis', the centre line is positioned by adjusting P10.

The next step is the positioning of the horizontal boundary. P12 is used to set the width, P11 to set the position. The vertical boundary can then be adjusted in the same way, using P14 and P13 for width and position respectively.

Having carried out these adjustments, switch S5 to 'hole-in-the-net'. Two holes should appear in the centre line, one corresponding to the vertical position of each bat. There is no adjustment for this, so if it does not work there must be a mistake in the wiring. . .

The last video adjustment is the correct positioning of the goals for 'football'. Switch S5 to 'football'; the height and position of the goals is set by P20 and P19 respectively. Finally the sound effects units must be adjusted. All NAND generators must be set on the verge of oscillation, by means of P15. . . P18.

The gain of IC23 is set with P21 to a comfortable level, where there is no audible distortion. **M**

17

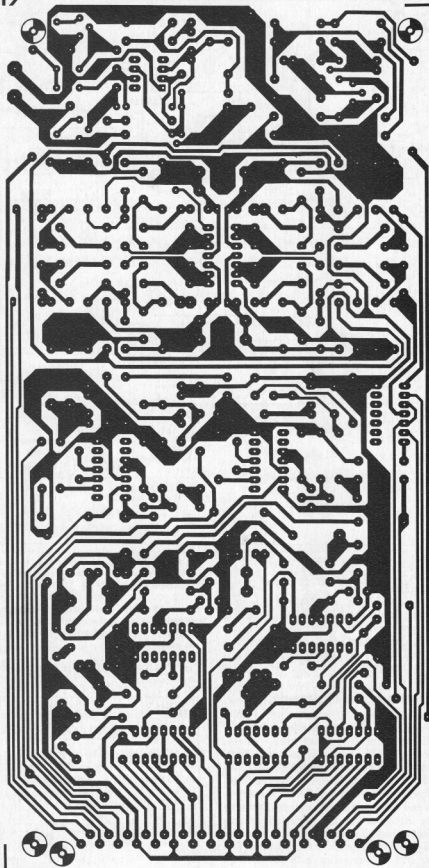

Resistors:

Figure 4:

R60, R62 = 100 k
R61, R64 = 10 k
R63 = 2k2
R65 = 330 Ω
P10 = 100 k (preset)

Figure 6:

R66, R68 = 100 k
R67 = 10 k
R69 = 2k2
R70 = 4k7
R71 = 330 Ω
R72 = 470 Ω

Parts list to figures 4, 6, 11, 15, 16 and 17

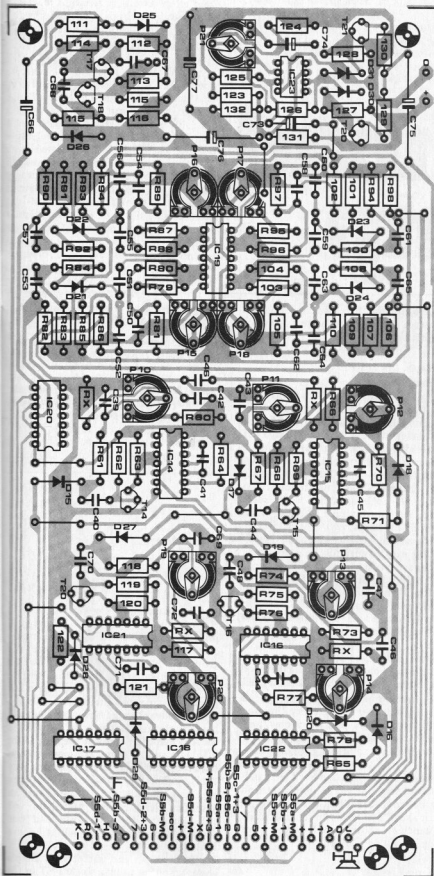

Figure 11:

R79, R87, R95, R103 = 150 k
 R80, R81, R88, R89, R96, R97, R104,
 R105 = 68 k
 R82, R90, R98, R106 = 12 k
 R83, R91, R99, R107 = 47 k
 R84, R92, R100, R108 = 27 k

R85, R93, R101, R109 = 10 k
 R86, R94, R102, R110, R115a,
 R116 = 390 k
 R111 = 470 Ω
 R112, R115 = 2k7
 R113, R114 = 270 k
 P15 . . . P18 = 470 k (preset)

Figure 15:
 R73, R75, R117, R119 = 100 k
 R74, R77, R118 = 10 k
 R76, R120 = 2k2
 R78 = 330 Ω
 R121 = 5k6
 R122 = 470 Ω

Figure 16:
 R123, R124 = 10 k
 R125, R126 = 100 k
 R127, R128 = 820 Ω
 R129, R130 = 12 Ω
 R131 = 100 Ω
 R132 = 1 k

$R_x = 1 \Omega (4x)$

Capacitors:

Figure 4:
 C39 = 470 n
 C40 = 1n5
 C41 = 82 p
 C42 = 100 n

Figure 6:
 C43, C44 = 470 n
 C45 = 820 n
 C46 = 100 n

Figure 11:
 C50, C53 . . . C58, C61, C62, C65 = 33 n
 C51, C52, C59, C60 = 10 n
 C63, C64 = 15 n
 C66 = 100 $\mu/10 V$
 C67, C68 = 100 n

Figure 15:
 C46a, C72 = 100 n
 C47, C69, C70 = 470 n
 C48 = 1n5

Figure 16:
 C73 = 1 μ 5/16 V
 C74 = 1 μ
 C75 = 220 μ /25 V
 C76 = 220 μ /16 V
 C77 = 100 μ /16 V

Semiconductors:

Figure 4:
 D15, D16 = DUS
 T14 = TUN
 IC14 = 74121

Figure 6:
 D17, D18 = DUS
 T15 = TUN
 IC15 = 74121

Figure 11:
 D21 . . . D26 = DUS
 T17, T18 = TUN
 IC19 = 4011
 IC20 = 7408

Figure 15:
 D19, D20, D27, D28 = DUS
 T16, T19 = TUN
 IC16, IC21 = 74121
 IC17 = 7474
 IC18 = 7400
 IC22 = 7408

Figure 16:
 D29, D30 = DUS
 T20 = BC141
 T21 = BC161
 IC23 = 741

Mechanical parts:

Figure 15:
 S5 = rotary switch 4-pole 3-way

Masthead Preamp

On the fringes of the service area of an AM transmitter it is often difficult to obtain satisfactory reception, especially of stereo transmissions, even when a good aerial and a first class FM tuner are used. In such cases a masthead aerial preamp may provide a solution.

It should be stressed from the outset that no aerial preamp will create a usable signal where the signal is virtually non-existent, or where it is obliterated by cosmic and man-made noise. Nor is an aerial preamp a substitute for a high-gain aerial system. What an aerial preamp can do is amplify a reasonably noise-free (albeit low-level) signal to a suitable level for feeding into the FM tuner. Since the preamp will introduce its own noise contribution it is important that a good aerial is used to provide the maximum input signal and thus ensure the best signal-to-noise ratio at the outset.

The preamp should be mounted on the masthead with the aerial for reasons that are readily apparent. There are inevitably losses in the aerial download. So far as the input signal is concerned it is irrelevant whether it is amplified first, then attenuated by the cable losses, or attenuated then amplified. It will still come out at the same level. If, however, the preamp is mounted on the masthead then its noise contribution will be attenuated by the cable losses, whereas if it is placed after the download the noise contribution will be unaffected.

Mounting the preamp on the masthead thus gives a better signal-to-noise ratio.

Types of preamp

As discussed in an earlier issue of Elektor (December 1974) aerial pre-amplifiers can be divided roughly into two categories — wide-band and tuned or tunable types. The advantage of wideband amplifiers is that an enormous frequency spectrum can be amplified without having to adjust the tuning when changing from one frequency to another. A single amplifier is then sufficient for use on the FM radio, VHF and UHF TV bands.

The disadvantages of wideband amplifiers are easy to guess. Since a very wide frequency spectrum is amplified (typically 80-890 MHz) the total signal amplitude is fairly high and cross-modulation easily results. It is also virtually impossible to design a wide-band amplifier to give an acceptable noise figure.

Tunable amplifiers suffer from none of these drawbacks and can be designed with higher gain than wideband types. The only practical disadvantage is that they must be tuned every time the station is changed, and for a masthead preamp this means varicap tuning.

A compromise solution is to use individual, broadly-tuned amplifiers for different frequency bands. The bandwidth of an FM aerial preamp need only be from something below 88 MHz to just above 108 MHz, all the unwanted frequencies above and below this bandpass will be rejected.

FET or Bipolar

The advantages and disadvantages of FET and bipolar transistors in similar applications have already been discussed (Tunable Aerial Amplifier, Elektor December 1974). In brief, at the frequencies in question, bipolar transistors offer higher gain than FET's, but their noise figure is higher and there is a greater possibility of cross-modulation.

Figure 1. An aerial preamp consisting of a single grounded-gate FET stage.

Figure 2. Arrangement of two stages like that of figure 1, back-to-back in a push-pull configuration.

Figure 3. Circuit of a complete push-pull aerial preamp. The additional stage increases the gain to around 25 dB.

For this reason FET's were chosen. Having decided on FET's, there still remains the choice of operating mode. The two modes of interest are the grounded source configuration, which offers high gain, and the grounded gate configuration, which has lower gain but is more stable and predictable. An additional advantage of the grounded gate configuration is, that whereas a grounded source amplifier can be designed for high gain or low noise (or a compromise between the two), in the grounded gate configuration the compromise between high gain and low noise is small (i.e. an amplifier designed for high gain will still have fairly low noise and one designed for low noise will still have fairly high gain).

Figure 1 shows the circuit of a simple aerial amplifier using a single FET in the grounded gate configuration. Unfortunately the gain is only three or four times and the amplifier must be tuned to each station. The gain may be increased by cascading two of these stages, as in the 'Tunable Aerial Amplifier' in Elektor 1, December 1974. However, it was decided to investigate what other possibilities were available, and the idea

of using a push-pull amplifier arose. Such an amplifier is shown in its basic form in figure 2, and offers considerable advantages.

It can easily be constructed using a dual FET. The Siliconix E430 is eminently suitable for this purpose. It consists of two type E310 FET's in a single package. These have a high transconductance (10 mA/V) and a noise figure of only 1.5 dB at 100 MHz. Furthermore, the input impedance of the grounded gate amplifier is about 120 Ω, so the input impedance of the push-pull amplifier is twice this (240 Ω). This is very convenient, as it means that the amplifier can be connected direct to a quarter wave folded dipole with only a small degree of mismatch. The input circuit need not be tuned and has the same bandwidth as the aerial. The output circuit can be broadly tuned with a passband centred on the middle of the FM band (around 95 MHz).

The circuit of figure 2 will provide a voltage gain of four or five and a good signal-to-noise ratio over the entire FM band without the need for any retuning. In many cases, however, more gain than this is required, so in the circuit of figure 3 the push-pull stage is followed by a second stage operating in the grounded-gate configuration.

The complete circuit operates as follows: the 300 Ω input is connected to points A and C. If an aerial with an integral

Table 1. Coil winding data.

Coil	Construction	Winding details
L1	self-supporting	5 turns 1 mm. silver-plated wire wound on 4 mm. dia. former. Tap at 2 1/2 turns.
L2	wound on 6 mm dia. former with ferrite core as specified.	primary winding 8 turns 0.6 mm. silver-plated wire. Tap at 4 turns. Secondary winding 2 turns 0.6 mm. enamelled copper wire.
L3	wound on 6 mm dia. former with ferrite core as specified.	primary winding 6 turns 0.6 mm. silver-plated wire. 300 Ω secondary 3 turns 0.6 mm. enamelled copper wire. 75 Ω secondary 1.5 turns 0.6 mm. enamelled copper wire.

balun transformer is used this will have a 75 Ω output, and this is connected to B and C. The 4 1N4148 diodes protect the amplifier against excessive input signals. Minimum noise contribution from the FET's is achieved when the drain current is about 5 mA, so R1 (nominally 220 Ω) must be selected to obtain this current. So that R1 and R2 have no effect on the input impedance chokes L4 and L5 are connected in series with these resistors. These offer a low impedance to d.c. but a high impedance at 100 MHz. The exact inductance of the chokes is not critical and may be anywhere between 10 and 100 μH, as long as they are both the same value.

The amplified signal is coupled into the final stage by an RF transformer L2. Since the noise figure of this stage is not so important it is designed for maximum gain and the overall voltage gain of the amplifier is around 18 (25 dB).

The output transformer L3 may have its secondary wound for an output impedance of either 300 Ω or 75 Ω. For the former the number of turns on the secondary is three and for the latter, one and a half turns.

Power Supply

If the circuit is to be used with an indoor aerial then it is usually possible to run separate supply leads. In this case the circuit must be decoupled from the

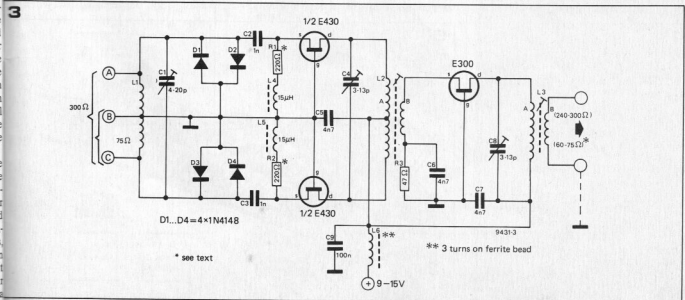
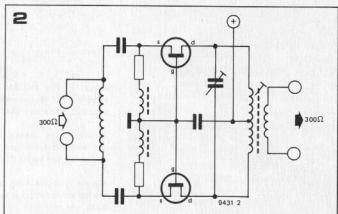
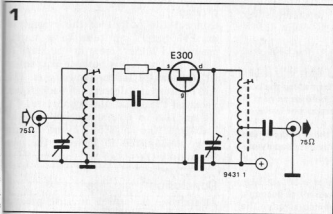

* see text

** 3 turns on ferrite bead

supply to avoid re-radiation of the signal from the supply leads. This is the function of C9 and L6, which consists of three turns of enamelled copper wire (diameter not critical) wound through a ferrite bead.

When the preamp is to be mounted on a rooftop aerial it is probably better to feed the supply voltage up the aerial downlead. To do this it is necessary to isolate the d.c. supply from the RF signal, as shown in figures 6 and 7. With a 75 Ω unbalanced downlead the supply positive is fed up the centre core while the earth connection is made to the braid. The 560p capacitors isolate the input of the FM tuner and the output of the aerial preamp from the d.c. supply, while the 5 μH chokes provide a high impedance to the RF signal so that it is not 'shorted out' by the low impedance of the supply.

For a 300 Ω downlead the situation is a little more complicated. Both sides of the cable are floating and there is no ground connection to the cable at the tuner or the preamp. For this reason it is necessary to isolate both sides of the downlead as shown. A further complication is, that since the 300 Ω twin feeder is symmetrical it is impossible to tell which lead is positive and which is negative unless a continuity check is carried out first. There then still remains the possibility of an error occurring if any changes are made at a later date. For this reason the supply is connected to the preamp via a bridge rectifier made up from 4 1N4148 diodes, so that whichever way round the cable is the preamp will always receive the correct supply polarity. The decoupling chokes can be home made by winding six or seven turns of enamelled wire through a ferrite bead.

According to the manufacturer's specification for the E430 the optimum supply voltage should be around 15 V, but the prototype functioned with supply voltages as low as 10 V with no noticeable change in gain or noise figure. The current taken by the preamp is around 20 mA max. so it may be possible to obtain the supply from the tuner

with which it is being used. If a circuit of the tuner is available it is a simple matter to find the positive supply connection to the tuner front-end, and the decoupling components can easily be mounted inside the tuner. For those not wishing to do this a simple stabilised supply can be made up using an IC voltage regulator such as the TBA625B or TBA625C.

Construction

Normal VHF construction practice should be followed when mounting the components on a (p.c.) board i.e. all component leads should be as short as possible. Figure 5 shows what the completed board should look like. Coil winding details are given in table 1. L1 is air-cored and is wound on a 4 mm diameter former (the refill of a ball-point pen was used for the prototype) which is then removed. L2 and L3 were wound on 6 mm diameter Kaschke coil formers type KHS/20-44/20 with a VHF ferrite slug model no. G5.0/75/16 type K3-12-100 colour code green. It is of course possible to use any other type of coil form (e.g. Neosid) provided the diameter is 6 mm and it has a VHF ferrite slug with permeability $\mu_r = 12$. The spacing between the turns is in all cases equal to the wire diameter. This spacing can easily be achieved by putting a bifilar winding on the former and then removing one of the windings. The primaries of L2 and L3 are wound using 0.5 or 0.6 mm diameter silver

plated wire, and the secondaries are then wound between the turns of the primaries using enamelled copper wire of the same diameter. To avoid interaction between L2 and L3 a tinplate screen should be mounted across the board as shown in figure 5. This should be grounded. All capacitors used in the construction should be high-quality ceramic types.

Alignment

Having constructed the circuit the current flowing through the FET's can be monitored by measuring the voltage across R1 and R2. For the correct current of 5 mA this should be about 1.1 V. If it is not then R1 and R2 should be changed to obtain the correct value (but note with values of R1 and R2 not 220 Ω the voltage drop for 5 mA current will be different, in fact V (volts) = $5 \times R1/2$ (k). Once the current is set the circuit can be connected up to an aerial. For optimum results the cable between the aerial and the preamp should be as short as possible, and in fact it is a good idea to modify the aerial connecting box to accommodate the preamp. If the aerial incorporates a balun (as do all aerials with 75 Ω output) then this may be dispensed with and connection made direct from the dipole to the 300 Ω input of the preamp. If one does not wish to do this then the output of the aerial balun may be fed into the 75 Ω input of the preamp.

Connect the output of the preamp to an FM tuner and tune to a station around 95 MHz. Screw in the slugs of L2 and L3 as far as possible and adjust C1, C4 and C8 for maximum gain. This will be heard as a decrease in background noise on the signal. Having adjusted C1, C4 and C8 to give minimum noise on the signal the slugs of L2 and L3 can now be adjusted to increase the gain (i.e. reduce the noise) still further.

Conclusion

As stated at the outset, an aerial preamp is no substitute for a good aerial, and should only be resorted to when an

Figure 4. Pin connections of the E430 dual FET.

Figure 5. For reliable performance, the construction of the preamp should be as neat as possible, with very short component leads.

Figure 6. By decoupling the RF signal and d.c. voltages from one another the supply can be fed up the aerial downlead.

Figure 7. Since both sides of a 300 Ω twin feeder are floating it is necessary to decouple both the positive and common supply. The bridge rectifier ensures that the supply to the preamp is always of the correct polarity.

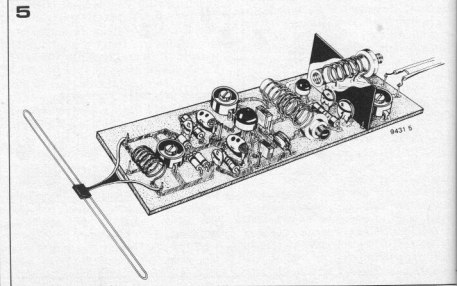
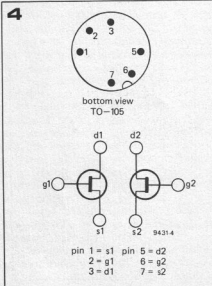

attempts to obtain a usable signal by installing a high-gain aerial have failed. Nevertheless this circuit will considerably improve reception in areas of low signal strength, or where it is not possible to mount the aerial in a position for optimum signal (as where flat-dwellers must use an indoor aerial).

The cross-modulation performance of the circuit is extremely good, and with the equipment available the noise figure of the prototype was unmeasurable (it was calculated at between 1.5 and 2 dB). The overload margin is also extremely good, and the preamp will happily handle input signals up to 1 V peak to peak. Finally, the gain of the prototype was about 25 dB, which is not to be sniffed at!

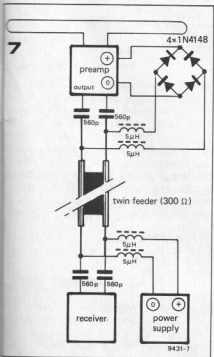
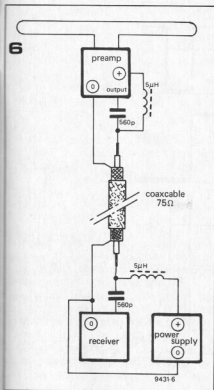

M. Vanhalst

VERSATILE LOGIC PROBE

A logic probe is a useful aid to testing and fault-finding digital circuits. The many commercial and amateur designs currently available all provide information about static logic states and a few also provide information about the dynamic behaviour of the circuit. The versatile logic probe provides information about logic levels and the duty-cycle of pulse trains in TTL and DTL circuits and is unusual in that it uses a 7-segment LED display for the readout, instead of the more usual discrete LED's.

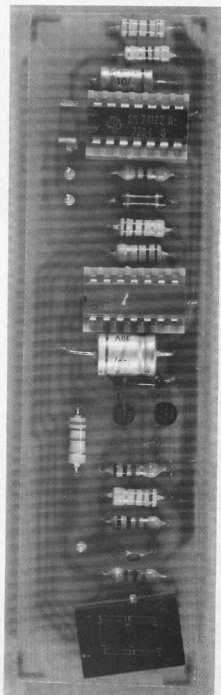
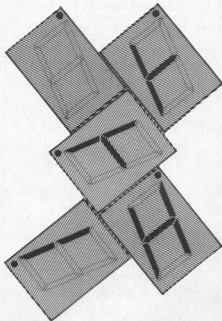

Figure 1 shows the readout provided by the logic display for various input conditions. The seven segment display is mounted on its side so that the normally vertical segments are horizontal. The various readout conditions are summarized below.

- a. No segments lit. Input voltage is higher than the maximum permitted '0' voltage, but lower than the minimum permitted '1' voltage. i.e. $0.8 \text{ V} < V_{in} < 2.4 \text{ V}$
- b. Upper segments only lit. Logic '1' level. Input voltage is greater than 2.4 V.
- c. to g. When a pulse train is present the middle vertical segment is lit. The upper and lower horizontal segments glow with a brightness depending on the duty-cycle. When the duty-cycle is very much greater than 50% the upper segments glow brightly and the lower segments are practically extinguished. As the duty-cycle is reduced the brightness of the lower segments increases until at 50% duty-cycle the upper and lower segments glow with equal brightness. At duty-cycles less than 50% the lower segments glow more brightly than the upper ones.
- h. Lower segments only lit. Logic '0' level. Input voltage less than 0.8 V.

The decimal point of the display lights as soon as power is applied to the probe circuit and thus acts as a supply indicator.

Operation of the circuit

The complete circuit of the versatile logic probe is given in figure 2. It operates as follows:

when a logic '0' (less than 0.8 V) is present at the input, both transistors are turned off. The input of N1 is thus high, and that of N2 is low, so the output of N1 is low and that of N2 is high and segments e and f are lit. Careful choice of biasing resistors for T1 and T2 ensures that if the input is left floating then T1 is turned on while T2 remains turned off. The outputs of both N1 and N2 are thus high and no segments are lit. The same is true if the input voltage lies between about 0.8 and 2.4 V. It may be necessary to alter the value of R3 slightly to obtain the '0' indication at exactly 0.8 V because of variations in gain and base-emitter voltage of different transistors.

Once the voltage on the input exceeds 2.4 V (logic '1' level) both transistors are turned on, the output of N2 goes low and the upper segments (b and c) light.

Dynamic Operation

It is evident from the foregoing that if a pulse train is applied to the input the upper and lower segments will light alternately as the input switches between logic '0' and '1'. If the pulse repetition frequency is high then the transition will be too fast for the eye

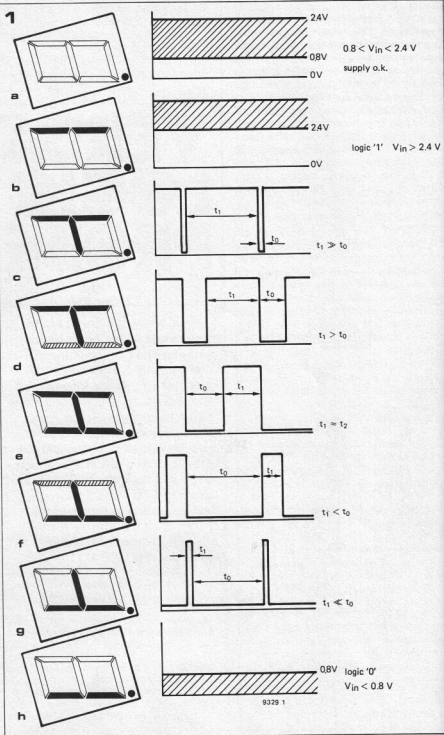

Parts list:

Resistors:
 R1 = 18 k
 R2, R5 = 10 k
 R3, R4, R10 = 1 k
 R6 = 330 Ω
 R7, R8 = 220 Ω
 R9, R12 = 470 Ω
 R11 = 27 k
 R13 = 1 Ω

Capacitors:
 C1 = 100 n
 C2, C3 = 10 p
 C4 = 10 μ /16 V
 C5 = 100 μ /6.3 V

Semiconductors:

IC1 = 7420
 IC2 = 74122
 T1, T2 = BF494
 (or BF194)
 7-segment
 display = MAN7, DL707,
 SLA1, 5082-7730

MARKET MARKET MARKET

LED clock displays

Two new multiple-digit, p.c.b. mounted numeric LED displays have been introduced by Litronix. The DL-4120A and DL-4520A each incorporate four 7-segment numeric LED displays mounted on a p.c.b. within a red polypropylene colour filter. The digit height of the -4520A is 1/2 in., and of the -4520A, 1 in. - the largest numeric LED displays currently available.

Designed principally for applications in 12-hour or 24-hour electronic digital clocks, the displays include colons for a.m., p.m. and Alarm Set indication, and feature excellent character definition at viewing distances in excess of 60 ft.

It is anticipated that the series will be extended in the near future to include end-stackable, dual-digit p.c.b. mounted display modules for applications such as t.v. channel indication, instrumentation read-outs, panel meters, etc.

Typical electrical characteristics of the DL-4520A include a forward voltage of 1.8 V at 20 mA per segment, and luminous intensity of 1.0 mod; the DL-4120A has a typical forward voltage of 3.6 V at 20 mA, and luminous intensity of 2.0 mod. Currently, the displays are available in development quantities: production prices are anticipated to

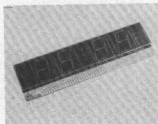

be £4.80 in the case of the DL-4520A, and £5.50 for the DL-4120A, in quantities of 100 to 999.

*Litronix House,
593 Hitchin Rd.,
Stopsley, Beds.*

Miniature proximity transducers

A new range of miniature proximity transducers available from Schaevitz EM Limited can be used in such applications as gauging the run-out of a rotating shaft resulting from bearing wear, and verifying the thickness and contour of the strip leaving a rolling mill. PT series transducers can also be used to detect the presence or absence of a ferrous material thereby functioning as a non-contacting sensor. These variable reluctance units are

precision electromagnetic devices that respond to the close presence of ferromagnetic objects and give an electrical output which is approximately inversely proportional to the distance between a ferromagnetic surface and the sensitive face of the transducer. There is no physical contact involved and measurements can be made with both lateral and radial motion, whether static or dynamic.

PT series units are 1.05 in (2.7 mm) long overall and are fully compatible with standard LVDT signal conditioning equipment. Typical full scale output is 100 mV/V with an excitation of 2.5 kHz at 7.5 V rms, and 125 mV/V with an excitation of 2 kHz at 10 V rms. Four linear ranges are available from 0.005 in (0.010 mm) to 0.050 in (0.100 mm) with quick delivery.

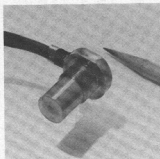

For those applications requiring a linear output, two closely matched proximity transducers are operated in a face-to-face arrangement. Each is equally spaced from opposite sides of the ferromagnetic strip being measured. The primaries are connected in series or parallel; secondaries are connected differentially in series-opposing mode. The output is similar to that from an AC LVDT and includes phase reversal through the null point.

*Schaevitz EM Limited
221 Bedford Avenue
Slough
Berkshire SL1 4RY*

New photoresist

Substantial improvements in the mass production of semiconductors and integrated circuits are claimed for a new ultra-pure, high viscosity positive photoresist manufactured by Micro-Image Technology Limited. This new MIT photoresist, known as Isofine HR, will provide manufacturers of electronic components with two main benefits. Firstly, the purity and high viscosity of the chemical greatly reduces the chance of damage to the chip during etching and so helps improve productivity by



increasing the yield from each batch produced. In addition the higher viscosities available will, it is claimed, give excellent step coverage, even when steps of up to 3 microns deep are being etched. Because of the photoresist's high spectral sensitivity to ultra-violet light sources these thicker layers still give fast exposure times and provide stable and reproducible images. The price of this new photoresist depends upon the viscosity specified and the quantities being ordered, but it will be in the area of £40 a litre, delivered UK.

*Micro-Image Technology
Greenhill Industrial Estate
Ridding, Derby, DE5 4UB.*

Low priced D/A converters

Datel Systems Model DAC-HY12DC is a new 3 BCD digit, hybrid digital to analog converter which is priced at just \$29.00 in single quantity. The converters are complete and ready to use, consisting of a precision zero current reference, monolithic quad current switches, a stable thin film resistor network, and a fast monolithic output amplifier. A key performance feature is pin-programmable output ranges. By this means unipolar output voltages of 0 to +5 V or 0 to +10 V are achieved; the units can also be

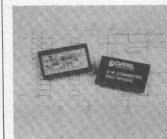

programmed for current output to give 0 to -1.25 mA. The CAD-HY12DC is cased in a miniature 1.3 x 0.8 x 0.15 inch glass package which is hermetically sealed.

These converters require only a ±15VDC supply for operation - no 5VDC power is needed. The inputs accept standard DTL/TTL logic and have complementary BCD coding. Provision is made for external adjustment of zero and full scale for precision alignment in a given application. Operating temperature range is 0°C to 70°C. Other specifications include settling times of 300 nsec. for current output and 3 μsec. for voltage output. Gain temperature coefficient is ±30 ppm/°C max. and tempo of zero is ±5 ppm/°C of full scale range. Due to precisely matched quad current switches and tightly tracking nichrome thin-film resistors, the differential linearity temperature coefficient is only ±2 ppm/°C of full scale range.

The gain error of these converters is 0.1% and the zero error is .05% without external trimming. Applications for these converters include data distribution systems, computer controlled waveform generation, automatic test equipment, precision ramp generators, and zero decay hold circuits.

*Datel Systems, Inc.
1020 Turnpike St.,
Canton, Mass. 02021 U.S.A.*

Sine-Wave Signal Generator

The SG 504 Leveled Sine-Wave Signal Generator is designed for calibrating oscilloscope amplifier bandpass up to and beyond today's state of the art in real-time oscilloscopes. An external leveling head provides a regulated, constant amplitude sine-wave out-



M6800 has taken the gamble out of microprocessors

Seven reasons why you'll always win with M6800.

1. **Programming language.**
So easily learned that it makes your transition to MPU's that much easier.
2. **Unlike competitive ranges, the M6800 family is capable of further development** while still maintaining upward compatibility.
Example: The M6900 series is now being defined to meet defined customers' requirements.
3. **Very efficient programme code.**
Wide instruction repertoire, including seven addressing modes.
4. **Sub-function devices already available.**
5. **Single power rail, 5 volt.**
6. **Interfaces easily with TTL and CMOS.**
7. **Second sourced by AMI across Europe.**

Here's the M6800 family today:—

MC6800	Microprocessor.
MC6820	Peripheral Interface Adapter.
MCM6810	Static RAM.
MCM6830	ROM.
MC6850	Asynchronous Communications Interface Adapter.
MC6860	Low Speed Modem.

Alternative N-Channel Si Gate RAMs for large systems:—

MCM68102	1K x 1 Static	16-pin.
MCM6814	4K x 1 Dynamic	16-pin.
MCM6815	4K x 1 Dynamic	22-pin.

Recent new devices include:—

Dynamic Memory Refresh Controller.		
MCM68112A	256 x 4 Static RAM.	16-pin.
MCM68317	16K Static ROM.	24-pin.

An 8K x 1 erasable and electrically reprogrammable ROM (MCM68708) was introduced in the first quarter of 1976. And there's more to come!



MOTOROLA
Semiconductors

Motorola Ltd. Semiconductor Products Division
York House, Empire Way, Wembley, Tel: 01-902 8836.